

BORMANN®



BBQ1140

024316



v2.2



WWW.NIKOLAOUTOOLS.GR

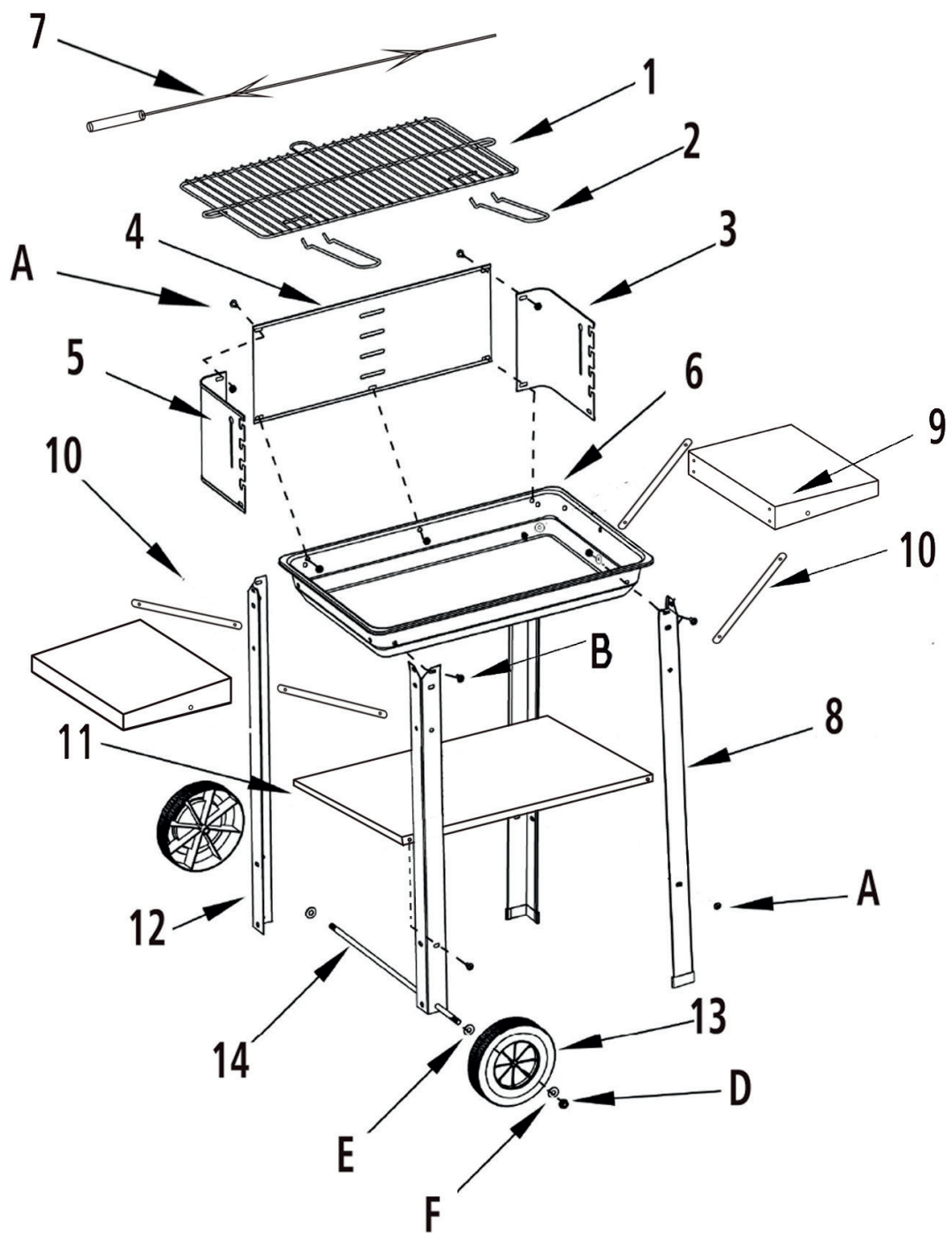

Safety Instructions



WARNING – High risk of burning injury!

- Make sure that the barbecue is standing on a flat and fireproof surface that is not made of glass or plastic.
- **CAUTION!** This barbecue becomes very hot and should not be carried while it is in use!
- Please wear oven gloves or use grilling tools when barbecuing.
- Allow the product to cool down completely before cleaning it.
- **CAUTION!** Do not use any chemicals, spirits or any type of flammable liquids to ignite or re-ignite the fire!
- **CAUTION!** Only use firelighters that correspond to the European Standard for firelighters (EN1860-3)!
- Never use water to extinguish the barbecue's charcoal.



WARNING - Risk of suffocation! Do not use this product in enclosed areas!



DANGER to children and pets! Never leave the hot barbecue unattended.
WARNING! Keep children and pets at a safe distance!



Please read the instructions of the manual carefully before you start using your **BORMANN** barbecue.

Proper utilisation

The barbecue may only be used for the preparation of suitable foods. All requirements of this operation manual must be complied with.



This product is designed for private use only!

Safe operation of the barbecue

The barbecue should be heated up for approximately 30 minutes before it is used for the first time.

Information for safe operation of the barbecue

The barbecue must be positioned on a stable and secure surface when it is in use.

Do not use in enclosed or covered areas.

The barbecue should be heated up for approximately 30 minutes before it is used for the first time.

Assembly instructions (see page 2)

General information for successful assembly

Please read the assembly instructions carefully and follow the safety precautions. Allow sufficient time for assembly.

Before starting assembly, clear an area measuring approximately two to three square metres. Remove the item from the packaging!

Lay out all of the parts and any necessary tools so that they are within easy reach.



Please note: Only tighten all of the screw connections firmly when you have finished assembly. Otherwise this can result in unwanted tension.

Step 1

- Install the legs (8 and 12), side boards (9), to the fire bowl (6) using screws (B) and nuts (C).
- Install the side board supports (10) to the bowl (6) using screws (A) and nuts (C).

Step 2

- Install the bottom board (11) to the legs (8 and 11), using screws (A) and nuts (C).

Step 3

- Install the axis (14) and wheels (13) using washers (E) and (F) and lock with nuts (D).

Step 4

- Install the wind shields (3)(4)(5) to the fire bowl using screws (A) and nuts (C).







Step 5

- Install the cooking grid (1) to the wind shields (3)(4)(5).

Step 6

- Install the skewer (7) to the wind shields.

Parts list (see page 2)

No.	Description	Qty	No.	Description	Qty	Letter	Description	Qty
1	Cooking grid	1	8	Long leg	2	A	Screw M5x10mm 	19
2	Grid handle	2	9	Side board	2	B	Screw M5x16mm 	12
3	Right windshield	1	10	Side board support	4	C	Nut M5 	31
4	Rear windshield	1	11	Bottom board	1	D	Lock nut 	2
5	Left windshield	1	12	Leg for wheel	2	E	Plastic washer M8 	2
6	Fire bowl	1	13	Wheel	2	F	Washer M8 	2
7	Skewer	1	14	Wheel axis	1			

Technical data

Cooking grid size: 49x29 cm

Gross weight: 7.1 kgs

Igniting the fuel

 **WARNING - risk of burning!** When petrol or white spirits are ignited uncontrollable heat can develop as a result of deflagration. You should therefore only use harmless fuel, such as firelighters. The barbecue must be positioned on a stable and secure surface when it is in use.

1. Stack some of the charcoal or briquettes in the fire bowl.
2. Ignite one or two solid firelighters using a long match. Place these firelighters on top of the layer of charcoal or briquettes.
3. Allow the solid firelighters to burn for 2 to 4 minutes. Then fill the fire bowl slowly with charcoal or briquettes.
4. A white layer of ash should develop on the fuel after approximately 15 to 20 minutes. This indicates that the optimal grilling condition has been reached. Distribute the fuel evenly in the fire bowl using a suitable metal tool.
5. Insert the greased grill and then you can start barbecuing.

Cleaning / Care

 **WARNING - risk of burning!** Allow the barbecue to cool down completely before cleaning it. Never use water to quench the hot barbecue. This could result in burning or scalding.

Occasional cleaning is necessary to preserve the beautiful appearance of the barbecue. Do not use any scouring agents.

1. A rinsing cloth and some water with a commercial detergent is sufficient for the normal cleaning process.
2. If the enamelled parts are heavily soiled, use a commercial enamel cleaning agent (oven cleaner). Observe the manufacturer's instructions for the cleaning agent being used.
3. Clean the grill using some washing-up liquid and a rust proof cleaning pad.

Environmental Protection & Disposal

Pay attention to cleanliness when using the barbecue and dispose of waste in a clean and safe manner. As a general rule, only dispose of waste in designated metal or non-flammable containers.

The local regulations for disposal apply.

* The manufacturer reserves the right to make minor changes to product design and technical specifications without prior notice unless these changes significantly affect the performance and safety of the products. The parts described / illustrated in the pages of the manual that you hold in your hands may also concern other models of the manufacturer's product line with similar features and may not be included in the product you just acquired.

* To ensure the safety and reliability of the product and the warranty validity, all repair, inspection, repair or replacement work, including maintenance and special adjustments, must only be carried out by technicians of the authorized service department of the manufacturer.

* Always use the product with the supplied equipment. Operation of the product with non-provided equipment may cause malfunctions or even serious injury or death. The manufacturer and the importer shall not be liable for injuries and damages resulting from the use of non-conforming equipment.

Instructions de sécurité



AVERTISSEMENT - Risque élevé de brûlure !

- Veillez à ce que le barbecue repose sur une surface plane et ignifuge qui n'est pas en verre ou en plastique.
- **ATTENTION !** Ce barbecue devient très chaud et ne doit pas être transporté lorsqu'il est utilisé !
- Veuillez porter des gants de cuisine ou utiliser des outils de grillade lorsque vous faites un barbecue.
- Laissez le produit refroidir complètement avant de le nettoyer.
- **ATTENTION !** N'utilisez pas de produits chimiques, d'alcools ou de tout autre type de liquide inflammable pour allumer ou rallumer le feu !
- **ATTENTION !** N'utilisez que des allume-feu correspondant à la norme européenne pour les allume-feu (EN1860-3) !
- N'utilisez jamais d'eau pour éteindre le charbon de bois du barbecue.



AVERTISSEMENT - Risque de suffocation ! N'utilisez pas ce produit dans des endroits fermés !



DANGER pour les enfants et les animaux domestiques ! Ne laissez jamais le barbecue chaud sans surveillance.
AVERTISSEMENT ! Maintenez les enfants et les animaux domestiques à une distance sûre !



Veillez lire attentivement les instructions du manuel avant de commencer à utiliser votre barbecue **BORMANN**.

Utilisation appropriée

Le barbecue ne doit être utilisé que pour la préparation d'aliments appropriés. Toutes les exigences de ce manuel d'utilisation doivent être respectées.



Ce produit est conçu pour un usage privé uniquement !

Utilisation sûre du barbecue

Le barbecue doit être chauffé pendant environ 30 minutes avant d'être utilisé pour la première fois.

Informations pour une utilisation sûre du barbecue

Le barbecue doit être placé sur une surface stable et sûre lorsqu'il est utilisé.

Ne pas utiliser dans des endroits clos ou couverts.

Le barbecue doit être chauffé pendant environ 30 minutes avant d'être utilisé pour la première fois.

Instructions de montage (voir page 2)

Informations générales pour un montage réussi

Veillez lire attentivement les instructions de montage et respecter les consignes de sécurité. Prévoyez suffisamment de temps pour le montage. Avant de commencer le montage, libérez une surface d'environ deux à trois mètres carrés. Retirez l'article de son emballage ! Disposez toutes les pièces et les outils nécessaires de manière à ce qu'ils soient facilement accessibles.



Remarque : Ne serrez fermement tous les raccords à vis que lorsque vous avez terminé le montage. Sinon, cela peut entraîner une tension indésirable.

Étape 1

- Installez les pieds (8 et 12), les planches latérales (9), sur la cuve (6) à l'aide des vis (B) et des écrous (C).
- Installer les supports des planches latérales (10) sur la cuve (6) à l'aide des vis (A) et des écrous (C).

Étape 2

- Installer la planche inférieure (11) aux pieds (8 et 11), à l'aide des vis (A) et des écrous (C).

Étape 3

- Installer l'axe (14) et les roues (13) à l'aide des rondelles (E) et (F) et fixer avec les écrous (D).

Étape 4

- Installer les pare-brise (3)(4)(5) sur la cuve à l'aide des vis (A) et des écrous (C).







Étape 5

- Installer la grille de cuisson (1) sur le pare-brise (3)(4)(5).

Étape 6

- Installer la brochette (7) sur les pare-brise.

Liste des pièces (voir page 2)

N°	Description	Qté	N°	Description	Qté	Let t e	Description	Qté
1	Grille de cuisson	1	8	Pied longue	2	A	Vis M5x10mm 	19
2	Poignée de la grille	2	9	Planche latérale	2	B	Vis M5x16mm 	12
3	Pare-brise droit	1	10	Support de planche latérale	4	C	Ecrou M5 	31
4	Pare-brise arrière	1	11	Planche inférieure	1	D	Contre-écrou 	2
5	Pare-brise gauche	1	12	Pied pour la roue	2	E	Rondelle en plastique M8 	2
6	Cuve	1	13	Roue	2	F	Rondelle M8 	2
7	Brochette	1	14	Axe de la roue	1			

Données techniques

Taille de la grille de cuisson: 49x29 cm

Poids brut: 7,1 kg

L'allumage du combustible



AVERTISSEMENT - risque de brûlure ! Lorsque de l'essence ou du white-spirit sont allumés, une chaleur incontrôlable peut se développer en raison de la déflagration. C'est pourquoi vous ne devez utiliser que des combustibles inoffensifs, tels que des allume-feu. Le barbecue doit être placé sur une surface stable et sûre lorsqu'il est utilisé.

- Empilez une partie du charbon de bois ou des briquettes dans la cuve.
- Allumez un ou deux allume-feu solides à l'aide d'une longue allumette. Placez ces allume-feu sur la couche de charbon de bois ou de briquettes.
- Laissez les allume-feu solides brûler pendant 2 à 4 minutes. Remplissez ensuite lentement la cuve avec du charbon de bois ou des briquettes.
- Une couche blanche de cendres doit se former sur le combustible après environ 15 à 20 minutes. Cela indique que les conditions optimales de grillage ont été atteintes. Répartissez uniformément le combustible dans la cuve à l'aide d'un outil métallique approprié.
- Insérez la grille graissée et vous pouvez commencer à faire des grillades.

Nettoyage / Entretien



AVERTISSEMENT - risque de brûlure ! Laissez le barbecue refroidir complètement avant de le nettoyer. N'utilisez jamais d'eau pour éteindre le barbecue chaud. Cela pourrait entraîner des brûlures ou des échaudures.

Un nettoyage occasionnel est nécessaire pour préserver la belle apparence du barbecue. N'utilisez pas de produits abrasifs.

- Un chiffon de rinçage et un peu d'eau avec un détergent commercial suffisent pour le nettoyage normal.
- Si les parties émaillées sont très sales, utilisez un produit de nettoyage pour émail du commerce (nettoyant pour four). Respectez les instructions du fabricant du produit de nettoyage utilisé.
- Nettoyez le gril à l'aide d'un peu de liquide vaisselle et d'un tampon de nettoyage antirouille.

Protection et élimination de l'environnement

Veillez à la propreté lorsque vous utilisez le barbecue et éliminez les déchets de manière propre et sûre. En règle générale, ne jetez les déchets que dans les récipients métalliques ou ininflammables prévus à cet effet.

Les réglementations locales en matière d'élimination s'appliquent.

* Le fabricant se réserve le droit d'apporter des modifications mineures à la conception et aux spécifications techniques des produits sans préavis, à moins que ces modifications n'affectent de manière significative les performances et la sécurité des produits. Les pièces décrites / illustrées dans les pages du manuel que vous tenez entre vos mains peuvent également concerner d'autres modèles de la gamme de produits du fabricant présentant des caractéristiques similaires et peuvent ne pas être incluses dans le produit que vous venez d'acquérir.

* Pour garantir la sécurité et la fiabilité du produit et la validité de la garantie, tous les travaux de réparation, d'inspection, de réparation ou de remplacement, y compris l'entretien et les réglages spéciaux, doivent être effectués uniquement par des techniciens du service après-vente agréé du fabricant.

* Utilisez toujours le produit avec l'équipement fourni. L'utilisation du produit avec un équipement non fourni peut entraîner des dysfonctionnements, voire des blessures graves ou mortelles. Le fabricant et l'importateur ne peuvent être tenus responsables des blessures et des dommages résultant de l'utilisation d'un équipement non conforme.

Istruzioni di sicurezza



AVVERTENZA - Alto rischio di ustioni!

- Assicurarsi che il barbecue sia posizionato su una superficie piana e ignifuga che non sia di vetro o plastica.
- **ATTENZIONE!** Questo barbecue diventa molto caldo e non deve essere trasportato mentre è in funzione!
- Indossare guanti da forno o utilizzare strumenti per la cottura alla griglia.
- Lasciare raffreddare completamente il prodotto prima di pulirlo.
- **ATTENZIONE!** Non utilizzare prodotti chimici, alcolici o qualsiasi tipo di liquido infiammabile per accendere o riaccendere il fuoco!
- **ATTENZIONE!** Utilizzare solo accendifuoco conformi alla norma europea per gli accendifuoco (EN1860-3)!
- Non utilizzare mai l'acqua per spegnere la carbonella del barbecue.



AVVERTENZA - Rischio di soffocamento! Non utilizzare questo prodotto in ambienti chiusi!



PERICOLO per bambini e animali domestici! Non lasciare mai incustodito il barbecue caldo.

ATTENZIONE! Tenere bambini e animali domestici a distanza di sicurezza!



Leggere attentamente le istruzioni del manuale prima di iniziare a utilizzare il barbecue **BORMANN**.

Utilizzo corretto

Il barbecue può essere utilizzato solo per la preparazione di cibi adatti. È necessario rispettare tutti i requisiti delle presenti istruzioni per l'uso.



Questo prodotto è destinato esclusivamente all'uso privato!

Funzionamento sicuro del barbecue

Il barbecue deve essere riscaldato per circa 30 minuti prima di essere utilizzato per la prima volta.

Informazioni per il funzionamento sicuro del barbecue

Il barbecue deve essere posizionato su una superficie stabile e sicura quando è in uso.

Non utilizzare in aree chiuse o coperte.

Il barbecue deve essere riscaldato per circa 30 minuti prima di essere utilizzato per la prima volta.

Istruzioni di montaggio (vedere pagina 2)

Informazioni generali per un montaggio corretto

Leggere attentamente le istruzioni di montaggio e seguire le precauzioni di sicurezza. Lasciare il tempo necessario per il montaggio. Prima di iniziare il montaggio, liberare un'area di circa due o tre metri quadrati. Togliere l'articolo dall'imballaggio! Disporre tutti i componenti e gli attrezzi necessari in modo che siano facilmente raggiungibili.



Attenzione: serrare saldamente tutte le viti solo al termine del montaggio. In caso contrario, potrebbero verificarsi tensioni indesiderate.

Passo 1

- Installare le gambe (8 e 12), le tavole laterali (9) e il braciere (6) con viti (B) e dadi (C).
- Installare i supporti delle tavole laterali (10) sul braciere (6) utilizzando viti (A) e dadi (C).

Passo 2

- Installare il tavolo di fondo (11) sulle gambe (8 e 11), utilizzando viti (A) e dadi (C).

Passo 3

- Installare l'asse (14) e le ruote (13) utilizzando le rondelle (E) e (F) e fissare con i dadi (D).

Passo 4

- Installare i parabrezza (3)(4)(5) sul braciere utilizzando le viti (A) e i dadi (C).







Passo 5

- Installare la griglia di cottura (1) sugli parabrezza (3)(4)(5).

Passo 6

- Installare lo spiedo (7) sugli parabrezza.

Elenco dei componenti (vedere pagina 2)

N°	Descrizione	Qtà	N°	Descrizione	Qtà	Le era	Descrizione	Qtà
1	Griglia di cottura	1	8	Gamba lunga	2	A	Vite M5x10mm 	19
2	Maniglia della griglia	2	9	Tavola laterale	2	B	Vite M5x16mm 	12
3	Parabrezza destro	1	10	Supporto della tavola laterale	4	C	Dado M5 	31
4	Parabrezza posteriore	1	11	Tavola di fondo	1	D	Dado di bloccaggio 	2
5	Parabrezza sinistro	1	12	Gamba per ruota	2	E	Rondella di plastica M8 	2
6	Braciere	1	13	Ruota	2	F	Rondella M8 	2
7	Spiedo	1	14	Asse della ruota	1			

Dati tecnici

Dimensioni griglia di cottura: 49x29 cm

Peso lordo: 7,1 kg

Accensione del carburante



AVVERTENZA - rischio di ustione! Quando si accende la benzina o l'acquaragia si può sviluppare un calore incontrollabile a causa della deflagrazione. Si consiglia pertanto di utilizzare solo combustibili innocui, come ad esempio gli accendifuoco. Il barbecue deve essere posizionato su una superficie stabile e sicura quando è in uso.

1. Accatastate un po' di carbonella o bricchette nel braciere.
2. Accendere uno o due accendini solidi con un fiammifero lungo. Posizionare questi accendini sopra lo strato di carbone o bricchette.
3. Lasciare bruciare gli accendifuoco solidi per 2-4 minuti. Quindi riempire lentamente il braciere con carbone di legna o bricchette.
4. Dopo circa 15-20 minuti, sul combustibile dovrebbe formarsi uno strato di cenere bianca. Ciò indica che è stata raggiunta la condizione ottimale per la cottura alla griglia. Distribuire uniformemente il combustibile nel braciere utilizzando un attrezzo metallico adatto.
5. Inserite la griglia unta e poi potete iniziare a grigliare.

Pulizia / Cura



AVVERTENZA - rischio di bruciature! Lasciare raffreddare completamente il barbecue prima di pulirlo. Non utilizzare mai acqua per spegnere il barbecue caldo. Ciò potrebbe causare ustioni o scottature.

Una pulizia occasionale è necessaria per preservare il bell'aspetto del barbecue. Non utilizzare agenti abrasivi.

1. Per la normale pulizia è sufficiente un panno di risciacquo e un po' d'acqua con un detergente commerciale.
2. Se le parti smaltate sono molto sporche, utilizzare un detergente commerciale per smalti (detergente per forni). Attenersi alle istruzioni del produttore del detergente utilizzato.
3. Pulire la griglia con un po' di detersivo e un tampone antiruggine.

Protezione e smaltimento dell'ambiente

Prestare attenzione alla pulizia durante l'uso del barbecue e smaltire i rifiuti in modo pulito e sicuro. Come regola generale, smaltire i rifiuti solo in appositi contenitori metallici o non infiammabili.

Si applicano le norme locali per lo smaltimento.

* Il produttore si riserva il diritto di apportare modifiche minori al design e alle specifiche tecniche del prodotto senza preavviso, a meno che tali modifiche non influiscano in modo significativo sulle prestazioni e sulla sicurezza dei prodotti. Le parti descritte/illustrate nelle pagine del manuale che avete tra le mani possono riguardare anche altri modelli della linea di prodotti del produttore con caratteristiche simili e potrebbero non essere incluse nel prodotto appena acquistato.

* Per garantire la sicurezza e l'affidabilità del prodotto e la validità della garanzia, tutti i lavori di riparazione, ispezione, riparazione o sostituzione, compresa la manutenzione e le regolazioni speciali, devono essere eseguiti esclusivamente da tecnici del servizio di assistenza autorizzato del produttore.

* Utilizzare sempre il prodotto con le apparecchiature in dotazione. L'utilizzo del prodotto con apparecchiature non in dotazione può causare malfunzionamenti o addirittura lesioni gravi o morte. Il produttore e l'importatore non sono responsabili per lesioni e danni derivanti dall'uso di apparecchiature non conformi.

Γενικές οδηγίες ασφαλείας



ΠΡΟΕΙΔΟΠΟΙΗΣΗ για εγκαύματα!

- Βεβαιωθείτε ότι η ψησταριά βρίσκεται πάνω σε μια επίπεδη και πυράντοχη επιφάνεια, η οποία δεν αποτελείται από γυαλί ή πλαστικό.
- **ΠΡΟΣΟΧΗ!** Στην ψησταριά αυτή αναπτύσσονται πολύ υψηλές θερμοκρασίες και δεν επιτρέπεται η μετακίνησή της κατά τη λειτουργία της!
- Φοράτε κατά το ψήσιμο γάντια ψησίματος ή χρησιμοποιήστε τσιμπίδα ή κάποιο άλλο αξεσουάρ barbecue.
- Αφήστε την ψησταριά να κρυώσει τελείως πριν από τον καθαρισμό της.
- **ΠΡΟΣΟΧΗ!** Μη χρησιμοποιείτε οινόπνευμα ή βενζίνη για το αρχικό ή ενδιάμεσο άναμμα!
- **ΠΡΟΣΟΧΗ!** Χρησιμοποιείτε μόνο προσανάμματα σύμφωνα με το ευρωπαϊκό πρότυπο για προσανάμματα (EN 1860-3)!
- Μη χρησιμοποιείτε ποτέ νερό για να σβήσετε τα ξυλοκάρβουνα.



ΠΡΟΕΙΔΟΠΟΙΗΣΗ ΚΙΝΔΥΝΟΥ ΑΣΦΥΞΙΑΣ! Μην χρησιμοποιείτε την ψησταριά σε κλειστούς χώρους!



ΚΙΝΔΥΝΟΣ για παιδιά και κατοικίδια!

Ποτέ μην αφήνετε χωρίς επίβλεψη την ψησταριά κατά την διάρκεια της λειτουργίας της.
ΠΡΟΣΟΧΗ! Κρατήστε τα παιδιά και τα κατοικίδια σε απόσταση ασφαλείας!



Πριν χρησιμοποιήσετε την ψησταριά της **BORMANN**, διαβάστε προσεκτικά τις παρούσες οδηγίες χρήσης.

Ενδεδειγμένη χρήση

Η ψησταριά επιτρέπεται να χρησιμοποιείται αποκλειστικά και μόνο για την παρασκευή τροφίμων που ψήνονται. Πρέπει να τηρούνται όλα όσα αναφέρονται στις παρούσες οδηγίες.



Μόνο για ιδιωτική χρήση!

Ασφαλής λειτουργία της ψησταριάς

Πριν από την πρώτη χρήση πρέπει να προθερμάνετε την ψησταριά για περ. 30 λεπτά.

Οδηγίες για την ασφαλή λειτουργία της ψησταριάς

Η ψησταριά πρέπει κατά τη διάρκεια της λειτουργίας να έχει ευστάθεια και να στηρίζεται πάνω σε σταθερό έδαφος/δάπεδο. Μην τη χρησιμοποιείτε σε κλειστούς ή στενασμένους χώρους. Χρησιμοποιείτε μόνο ασφαλή προσανάμματα. Πριν από την πρώτη χρήση θα πρέπει να προθερμάνετε την ψησταριά για περ. 30 λεπτά.

Οδηγίες συναρμολόγησης (βλέπε σελίδα 2)

Γενικές οδηγίες για επιτυχή συναρμολόγηση

Διαβάστε προσεκτικά τις οδηγίες συναρμολόγησης και ακολουθήστε τις υποδείξεις ασφαλείας. Φροντίστε να έχετε αρκετό χρόνο για τη συναρμολόγηση. Δημιουργήστε προηγουμένως μία επίπεδη επιφάνεια περίπου δύο έως τριών τετραγωνικών μέτρων. Αφαιρέστε τη συσκευή από τη συσκευασία! Φέρτε κοντά σας τα εξαρτήματα και τα απαραίτητα εργαλεία.

 **Προσέξτε:** Σφίξτε καλά όλες τις βίδες μόνο αφού ολοκληρώσετε τη συναρμολόγηση. Διαφορετικά ενδέχεται να παρουσιαστούν ανεπιθύμητες τάσεις.

Βήμα 1

- Στερεώστε τα πόδια (8 και 12) και τα πλαϊνά τραπέζια (9), στην εστία (6) χρησιμοποιώντας βίδες (B) και παξιμάδια (Γ).
- Στερεώστε τα στηρίγματα των πλαϊνών τραπέζιων (10) στην εστία (6) χρησιμοποιώντας βίδες (A) και παξιμάδια (Γ).

Βήμα 2

- Στερεώστε το κάτω τραπέζι (11) στα πόδια (8 και 11), χρησιμοποιώντας βίδες (A) και παξιμάδια (Γ).

Βήμα 3

- Τοποθετήστε τον άξονα (14) και τους τροχούς (13) χρησιμοποιώντας ροδέλες (E) και (F) και ασφαλίστε με παξιμάδια (D).

Βήμα 4

- Εγκαταστήστε την αντιανεμική προστασία (3)(4)(5) στην εστία χρησιμοποιώντας βίδες (A) και παξιμάδια (Γ).







Βήμα 5

- Τοποθετήστε τη σχάρα ψησίματος (1) στην αντιανεμική προστασία (3)(4)(5).

Βήμα 6

- Τοποθετήστε τη σούβλα (7) στην αντιανεμική προστασία.

Λίστα εξαρτημάτων (βλέπε σελίδα 2)

No.	Περιγραφή	Τεμ.	No.	Περιγραφή	Τεμ.	Γράμμα	Περιγραφή	Τεμ.
1	Σχάρα ψησίματος	1	8	Μακρύ πόδι	2	A	Βίδα M5x10mm 	19
2	Λαβή σχάρας	2	9	Πλαϊνό τραπέζι	2	B	Βίδα M5x16mm 	12
3	Αντιανεμική προστασία (δεξιό τμήμα)	1	10	Στήριγμα τραπέζιου	4	C	Παξιμάδι M5 	31
4	Αντιανεμική προστασία (οπίσθιο τμήμα)	1	11	Κάτω τραπέζι	1	D	Παξιμάδι ασφάλισης 	2
5	Αντιανεμική προστασία (αριστερό τμήμα)	1	12	Πόδι τροχού	2	E	Πλαστική ροδέλα M8 	2
6	Εστία	1	13	Τροχός	2	F	Ροδέλα M8 	2
7	Σούβλα	1	14	Άξονας τροχού	1			

Τεχνικά χαρακτηριστικά

Επιφάνεια ψησίματος: 49x29 cm

Βάρος: 7,1 kgs

Άναμμα καύσιμης ύλης



ΠΡΟΕΙΔΟΠΟΙΗΣΗ κινδύνου πρόκλησης εγκαυμάτων!

Κατά το άναμμα με βενζίνη ή οινόπνευμα μπορεί να προκληθούν ανεξέλεγκτες φλόγες. Χρησιμοποιείτε μόνο ακίνδυνα υλικά καύσης, όπως π.χ. στερεά προσανάμματα. Η ψησταριά πρέπει κατά τη διάρκεια της λειτουργίας να έχει ευστάθεια και να στηρίζεται πάνω σε σταθερό υπόστρωμα.

Βάλτε ένα μέρος των ξυλοκάρβουνων ή των μπρικετών στην εστία.

Ανάψτε ένα έως δύο στερεά προσανάμματα με ένα σπίρτο. Ακουμπήστε τα πάνω στο στρώμα από ξυλοκάρβουνα ή μπρικέτες που υπάρχει ήδη.

Αφήστε το στερεό προσάναμμα να καεί για 2 έως 4 λεπτά. Γεμίστε στη συνέχεια σιγά-σιγά την εστία με ξυλοκάρβουνα ή μπρικέτες! Μετά από περ. 15 έως 20 λεπτά θα δημιουργηθεί λευκή στάχτη πάνω στα κάρβουνα. Αυτό σημαίνει ότι έχουν πυρώσει.

Απλώστε ομοιόμορφα, με κατάλληλο μεταλλικό εργαλείο, τα κάρβουνα στην εστία.

Τοποθετήστε τη λαδωμένη σχάρα ψησίματος κι αρχίστε το ψήσιμο.

Καθαρισμός / φροντίδα



ΠΡΟΕΙΔΟΠΟΙΗΣΗ κινδύνου πρόκλησης εγκαυμάτων!

Αφήστε την ψησταριά να κρυώσει τελείως πριν από τον καθαρισμό. Μη χρησιμοποιείτε ποτέ νερό για να σβήσετε την ψησταριά όσο καίει ακόμη. Διαφορετικά θα υποστείτε εγκαύματα.

Για τη διατήρηση της καλής εμφάνισης είναι φυσικά απαραίτητος ο καθαρισμός. Μη χρησιμοποιείτε υλικά που χαράζουν.

1. Για τον κανονικό καθαρισμό επαρκεί ένα πανί για τα πιάτα και νερό με κοινό απορρυπαντικό πιάτων.
2. Εάν τα εμαγιέ σημεία έχουν λερωθεί πολύ, χρησιμοποιήστε ένα καθαριστικό για εμαγιέ του εμπορίου (καθαριστικό φούρνων). Ακολουθήστε τις οδηγίες του κατασκευαστή του καθαριστικού.
3. Καθαρίστε τη σχάρα ψησίματος με απορρυπαντικό πιάτων και ανοξειδωτο σφουγγάρι.

Προστασία περιβάλλοντος

Φροντίστε να υπάρχει καθαριότητα κατά τον χειρισμό της ψησταριάς και κατά την απόρριψη των υπολειπόμενων υλικών.

Πετάξτε τα υπόλοιπα σκουπίδια μόνο σε προβλεπόμενους κάδους από μέταλλο ή για άφλεκτα υλικά.

Ισχύουν οι τοπικές διατάξεις για τη διάθεση των απορριμμάτων.

*Ο κατασκευαστής διατηρεί το δικαίωμα να πραγματοποιήσει δευτερεύουσες αλλαγές στο σχεδιασμό του προϊόντος και στα τεχνικά χαρακτηριστικά χωρίς προηγούμενη ειδοποίηση, εκτός εάν οι αλλαγές αυτές επηρεάζουν σημαντικά την απόδοση και λειτουργία ασφάλειας των προϊόντων. Τα εξαρτήματα που περιγράφονται / απεικονίζονται στις σελίδες του εγχειριδίου που κρατάτε στα χέρια σας ενδέχεται να αφορούν και σε άλλα μοντέλα της σειράς προϊόντων του κατασκευαστή, με παρόμοια χαρακτηριστικά, και ενδέχεται να μην περιλαμβάνονται στο προϊόν που μόλις αποκτήσατε.

* Για να διασφαλιστεί η ασφάλεια και η αξιοπιστία του προϊόντος καθώς και η ισχύς της εγγύησης όλες οι εργασίες επιδιόρθωσης, ελέγχου, επισκευής ή αντικατάστασης συμπεριλαμβανομένης της συντήρησης και των ειδικών ρυθμίσεων, πρέπει να εκτελούνται μόνο από τεχνικούς του εξουσιοδοτημένου τμήματος Service του κατασκευαστή.

* Χρησιμοποιείτε πάντα το προϊόν με τον παρεχόμενο εξοπλισμό. Η λειτουργία του προϊόντος με μη-προβλεπόμενο εξοπλισμό ενδέχεται να προκαλέσει βλάβη ή ακόμα και σοβαρό τραυματισμό ή θάνατο. Ο κατασκευαστής και ο εισαγωγέας ουδεμία ευθύνη φέρει για τραυματισμούς και βλάβες που προκύπτουν από την χρήση μη προβλεπόμενου εξοπλισμού.

Инструкции за безопасност



ПРЕДУПРЕЖДЕНИЕ - висок риск от изгаряне!

- Уверете се, че барбекюто е поставено върху равна и огнеупорна повърхност, която не е изработена от стъкло или пластмаса.
- **ВНИМАНИЕ!** Това барбекю става много горещо и не трябва да се пренася, докато се използва!
- Моля, носете кухненски ръкавици или използвайте инструменти за печене на скара, когато приготвяте барбекю.
- Оставете продукта да изстине напълно, преди да го почистите.
- **ВНИМАНИЕ!** Не използвайте никакви химикали, спиртни напитки или друг вид запалими течности за запалване или повторно запалване на огъня!
- **ВНИМАНИЕ!** Използвайте само запалки, които отговарят на изискванията на Европейския стандарт за запалки (EN1860-3)!
- Никога не използвайте вода за гасене на дървените въглища в барбекюто.



ПРЕДУПРЕЖДЕНИЕ - Опасност от задушаване! Не използвайте този продукт в затворени помещения!



ОПАСНОСТ за деца и домашни любимци! Никога не оставяйте горещото барбекю без надзор.
ПРЕДУПРЕЖДЕНИЕ! Дръжте децата и домашните любимци на безопасно разстояние!



Моля, прочетете внимателно инструкциите в ръководството, преди да започнете да използвате вашето барбекю **BORMANN**.

Правилно използване

Барбекюто може да се използва само за приготвяне на подходящи храни. Трябва да се спазват всички изисквания на това ръководство за експлоатация.



Този продукт е предназначен само за лична употреба!

Безопасна работа с барбекюто

Преди да използвате барбекюто за първи път, то трябва да се загрее за около 30 минути.

Информация за безопасна работа с барбекюто

Когато се използва, барбекюто трябва да бъде поставено на стабилна и сигурна повърхност.

Не използвайте в затворени или покрити помещения.

Преди да използвате барбекюто за първи път, то трябва да се загрее за около 30 минути.

Инструкции за сглобяване (вж. страница 2)

Обща информация за успешен монтаж

Моля, прочетете внимателно инструкциите за сглобяване и спазвайте предпазните мерки за безопасност. Осигурете достатъчно време за сглобяване. Преди да започнете сглобяването, разчистете площ с размери приблизително два до три квадратни метра. Извадете изделието от опаковката! Разположете всички части и всички необходими инструменти така, че да са на леснодостъпно място.



Моля, обърнете внимание: Затегнете здраво всички винтови съединения едва след като приключите монтажа.

В противен случай това може да доведе до нежелано напрежение.

Стъпка 1

- Монтирайте краката (8 и 12), страничните дъски (9) към купата за огън (6), като използвате винтове (B) и гайки (C).

- Монтирайте опорите на страничните дъски (10) към купата (6), като използвате винтове (A) и гайки (B).

Стъпка 2

- Монтирайте долната дъска (11) към краката (8 и 11), като използвате винтове (A) и гайки (C).

Стъпка 3

- Монтирайте оста (14) и колелата (13), като използвате шайби (E) и (F) и ги застопорите с гайки (D).

Стъпка 4

- Монтирайте предните стъкла (3)(4)(5) към купата за огън, като използвате винтове (A) и гайки (C).

Стъпка 5

- Монтирайте решетката за печене (1) към предните стъкла (3)(4)(5).

Стъпка 6

- Монтирайте шишовете (7) към предните стъкла.

Списък на частите (вж. страница 2)

№	Описание	Брой	№	Описание	Брой	Буква	Описание	Брой
1	Решетка за печене	1	8	Дълъг крак	2	A	Винт М5х10мм	19
2	Дръжка на решетката	2	9	Странична дъска	2	B	Винт М5х16мм	12
3	Дясно предно стъкло	1	10	Опора на страничната дъска	4	C	Гайка М5	31
4	Задно предно стъкло	1	11	Долна дъска	1	D	Заклучваща гайка	2
5	Ляво предно стъкло	1	12	Крак за колело	2	E	Пластмасова шайба М8	2
6	Купа за огън	1	13	Колело	2	F	Шайба М8	2
7	Шишове	1	14	Ос на колелото	1			

Технически данни

Размер на решетката за печене: 49x29 см
Брутно тегло: 7,1 кг

Запалване на горивото



ПРЕДУПРЕЖДЕНИЕ - риск от изгаряне! При запалване на бензин или бял спирт може да се получи неконтролируема топлина в резултат на дефлаграция. Поради това трябва да използвате само безвредно гориво, като например запалки. Барбекютото трябва да бъде поставено върху стабилна и сигурна повърхност, когато се използва.

- Сложете част от дървените въглища или брикетите в купата за огън.
- Запалете една или две твърди подпалки с помощта на дълга запалка. Поставете тези запалки върху слоя дървени въглища или брикети.
- Оставете твърдите подпалки да горят в продължение на 2 до 4 минути. След това бавно напълнете купата за огън с дървени въглища или брикети.
- След около 15 до 20 минути върху горивото трябва да се образува бял слой пепел. Това показва, че е постигнато оптимално състояние на грила. Разпределете равномерно горивото в купата за огън с помощта на подходящ метален инструмент.
- Поставете намазаната с мазнина скара и започнете да печете на барбекю.

Почистване / грижи



ПРЕДУПРЕЖДЕНИЕ - риск от изгаряне! Оставете барбекютото да изстине напълно, преди да го почистите. Никога не използвайте вода за гасене на горещото барбекю. Това може да доведе до изгаряне или опарване.

Необходимо е периодично почистване, за да се запази красивият външен вид на барбекютото. Не използвайте никакви почистващи препарати.

- За нормалното почистване е достатъчна кърпа за изплакване и малко вода с препарат от търговската мрежа.
- Ако емайлираните части са силно замърсени, използвайте универсален препарат за почистване на емайл (препарат за почистване на фурни). Спазвайте инструкциите на производителя за използвания почистващ препарат.
- Почистете скарата с помощта на течност за миене на съдове и антикорозионна подложка за почистване.

Опазване на околната среда и изхвърляне

Обръщайте внимание на чистотата, когато използвате барбекютото, и изхвърляйте отпадъците по чист и безопасен начин. Като общо правило изхвърляйте отпадъците само в определените за целта метални или незапалими контейнери. Прилагат се местните разпоредби за изхвърляне.

* Производителят си запазва правото да прави незначителни промени в дизайна и техническите спецификации на продуктите без предварително уведомление, освен ако тези промени не засягат значително работата и безопасността на продуктите. Частите, описани/илюстрирани на страниците на ръководството, което държите в ръцете си, може да се отнасят и за други модели от продуктовата линия на производителя с подобни характеристики и може да не са включени в току-що придобития от вас продукт.

* За да се гарантира безопасността и надеждността на продукта, както и валидността на гаранцията, всички дейности по ремонт, проверка, поправка или замяна, включително поддръжка и специални настройки, трябва да се извършват само от техници от оторизирания сервизен отдел на производителя.

* Винаги използвайте продукта с доставеното оборудване. Работата на продукта с неосигурено оборудване може да доведе до неизправности или дори до сериозни наранявания или смърт. Производителят и вносителят не носят отговорност за наранявания и щети, възникнали в резултат на използването на несъответстващо на изискванията оборудване.

Varnostna navodila



OPOZORILO - velika nevarnost opeklinških poškodb!

- Prepričajte se, da žar stoji na ravni in ognjevarni površini, ki ni izdelana iz stekla ali plastike.
- **POZOR!** Ta žar se zelo segreje in ga med uporabo ne smete prenašati!
- Pri peki na žaru nosite rokavice ali uporabite orodje za peko na žaru.
- Pred čiščenjem izdelka počakajte, da se popolnoma ohladi.
- **POZOR!** Za vžig ali ponovno vžiganje ognja ne uporabljajte nobenih kemikalij, žganih pijač ali kakršnih koli vnetljivih tekočin!
- **POZOR!** Uporabljajte samo vžigalnike, ki ustrezajo evropskemu standardu za vžigalnike (EN1860-3)!
- Za gašenje oglja na žaru nikoli ne uporabljajte vode.



OPOZORILO - nevarnost zadušitve! Izdelka ne uporabljajte v zaprtih prostorih!



NEVARNOST za otroke in hišne ljubljence! Vročega žara nikoli ne puščajte brez nadzora.
OPOZORILO! Otroke in hišne ljubljence držite na varni razdalji!



Pred začetkom uporabe žara **BORMANN** natančno preberite navodila v priročniku.

Pravilna uporaba

Žar lahko uporabljate le za pripravo primernih jedi. Upoštevati je treba vse zahteve iz tega priročnika za uporabo.



Ta izdelek je namenjen samo za zasebno uporabo!

Varno delovanje žara

Pred prvo uporabo je treba žar segrevati približno 30 minut.

Informacije za varno uporabo žara

Žar mora biti med uporabo postavljen na stabilno in varno površino.

Ne uporabljajte ga v zaprtih ali pokritih prostorih.

Pred prvo uporabo je treba žar segrevati približno 30 minut.

Navodila za sestavljanje (glejte stran 2)

Splošne informacije za uspešno montažo

Pozorno preberite navodila za montažo in upoštevajte varnostne ukrepe. Za montažo si vzemite dovolj časa.

Pred začetkom montaže počistite prostor, velik približno dva do tri kvadratne metre. Izdelek vzemite iz embalaže!

Vse dele in morebitno potrebno orodje razporedite tako, da bodo na dosegu roke.



Opozorilo: Vse vijajčne spoje trdno zategnite šele po končani montaži. V nasprotnem primeru lahko pride do neželene napetosti.

Korak 1

- Z vijaki (B) in maticami (C) namestite nogi (8 in 12) ter stranski deski (9) na posodo za oglje (6).
- Namestite nosilce stranskih desk (10) na posodo (6) z vijaki (A) in maticami (C).

Korak 2

- Z vijaki (A) in maticami (C) pritrdite spodnjo desko (11) na nogi (8 in 11).

Korak 3

- Namestite os (14) in kolesa (13) s pomočjo podložk (E) in (F) ter jih zaklenite z maticami (D).

Korak 4

- Namestite vetrobranska stekla (3)(4)(5) na posodo za oglje z vijaki (A) in maticami (C).

Korak 5

- Na vetrobranska stekla (3)(4)(5) namestite rešetko za kuhanje (1).







Korak 6

- Na vetrobranska stekla pritrdite nabodalo (7).

Seznam delov (glej stran 2)

Št.	Opis	Kosi
1	Rešetka za kuhanje	1
2	Ročaj rešetke	2
3	Desno vetrobransko steklo	1
4	Zadnje vetrobransko steklo	1
5	Levo vetrobransko steklo	1
6	Posoda za oglje	1
7	Nabodalo	1

Št.	Opis	Kosi
8	Dolga noga	2
9	Stranska deska	2
10	Podpora za stransko desko	4
11	Spodnja deska	1
12	Noga za kolo	2
13	Kolo	2
14	Os kolesa	1

Črka	Opis	Kosi
A	Vijak M5x10 mm 	19
B	Vijak M5x16mm 	12
C	Matica M5 	31
D	Zaščitna matica 	2
E	Plastična podložka M8 	2
F	Podložka M8 	2

Tehnični podatki

Velikost rešetke za kuhanje: 49x29 cm

Bruto teža: 7,1 kg

Vžig goriva



OPOZORILO - nevarnost opeklin! Pri vžigu bencina ali belega špirita lahko zaradi deflagracije nastane nenadzorovana vročina. Zato smete uporabljati le neškodljivo gorivo, kot so vžigalniki. Žar mora biti med uporabo postavljen na stabilno in varno površino.

1. Nekaj oglja ali briketov zložite v posodo za oglje.
2. Z dolgo vžigalico vžgite enega ali dva trdna vžigalnika. Te vžigalnike položite na plast oglja ali briketov.
3. Počakajte, da trdni vžigalniki gorijo od 2 do 4 minute. Nato počasi napolnite posodo z ogljem ali briketi.
4. Po približno 15 do 20 minutah se mora na gorivu pojaviti bela plast pepela. To pomeni, da so bile dosežene optimalne razmere za peko na žaru. Z ustreznim kovinskim orodjem enakomerno porazdelite gorivo v posodo za oglje.
5. Vstavite namaščen žar in nato lahko začnete peči na žaru.

Čiščenje / nega



OPOZORILO - nevarnost opeklin! Pred čiščenjem žara počakajte, da se popolnoma ohladi. Za gašenje vročega žara nikoli ne uporabljajte vode. To lahko povzroči opekline ali opekline.

Za ohranitev lepega videza žara je potrebno občasno čiščenje. Ne uporabljajte sredstev za čiščenje.

1. Za običajno čiščenje zadostuje krpa za izpiranje in nekaj vode s komercialnim čistilnim sredstvom.
2. Če so emajlirani deli močno umazani, uporabite komercialno sredstvo za čiščenje emajla (čistilo za pečice). Upoštevajte navodila proizvajalca za uporabljenno čistilno sredstvo.
3. Žar očistite s tekočino za pomivanje posode in nerjavno čistilno blazinico.

Varstvo okolja in odstranjevanje

Pri uporabi žara bodite pozorni na čistočo, odpadke pa odlagajte na čist in varen način. Odpadke praviloma odlagajte le v za to namenjene kovinske ali nevnetljive posode.

Za odstranjevanje veljajo lokalni predpisi.

* Proizvajalec si pridržuje pravico do manjših sprememb zasnove in tehničnih specifikacij izdelka brez predhodnega obvestila, razen če te spremembe bistveno vplivajo na delovanje in varnost izdelkov. Deli, opisani/prikazani na straneh priručnika, ki ga držite v rokah, se lahko nanašajo tudi na druge modele proizvajalčeve linije izdelkov s podobnimi lastnostmi in morda niso vključeni v izdelek, ki ste ga pravkar pridobili.

* Da bi zagotovili varnost in zanesljivost izdelka ter veljavnost garancije, lahko vsa popravila, preglede, popravila ali zamenjave, vključno z vzdrževanjem in posebnimi nastavitvami, opravljajo le tehniki pooblaščenega servisnega oddelka proizvajalca.

* Izdelek vedno uporabljajte s priloženo opremo. Uporaba izdelka z opremo, ki ni priložena, lahko povzroči motnje v delovanju ali celo hude telesne poškodbe ali smrt. Proizvajalec in uvoznik nista odgovorna za poškodbe in škodo, ki so posledica uporabe neustrezne opreme.

Instrucțiuni de siguranță



AVERTISMENT - Risc ridicat de rănire prin ardere!

- Asigurați-vă că grătarul este așezat pe o suprafață plană și ignifugă, care nu este din sticlă sau plastic.
- **ATENȚIE!** Acest grătar devine foarte fierbinte și nu trebuie transportat în timp ce este în uz!
- Vă rugăm să purtați mănuși pentru cuptor sau să folosiți instrumente pentru grătar atunci când faceți grătar.
- Lăsați produsul să se răcească complet înainte de a-l curăța.
- **ATENȚIE!** Nu folosiți substanțe chimice, băuturi spirtoase sau orice tip de lichide inflamabile pentru a aprinde sau reaprinde focul!
- **ATENȚIE!** Utilizați numai brichete care corespund standardului european pentru brichete (EN1860-3)!
- Nu folosiți niciodată apă pentru a stinge cărbunele de pe grătar.



AVERTISMENT - Risc de sufocare! Nu utilizați acest produs în spații închise!



PERICOL pentru copii și animale de companie! Nu lăsați niciodată grătarul fierbinte nesupravegheat. AVERTISMENT! Păstrați copiii și animalele de companie la o distanță sigură!



Vă rugăm să citiți cu atenție instrucțiunile din manual înainte de a începe să folosiți grătarul **BORMANN**.

Utilizarea adecvată

Grătarul poate fi utilizat numai pentru prepararea de alimente adecvate. Trebuie respectate toate cerințele din acest manual de utilizare.



Acest produs este destinat exclusiv uzului privat!

Funcționarea în siguranță a grătarului

Grătarul trebuie încălzit timp de aproximativ 30 de minute înainte de a fi folosit pentru prima dată.

Informații pentru funcționarea în siguranță a grătarului

Grătarul trebuie să fie poziționat pe o suprafață stabilă și sigură atunci când este utilizat.

Nu îl utilizați în zone închise sau acoperite.

Grătarul trebuie încălzit timp de aproximativ 30 de minute înainte de a fi folosit pentru prima dată.

Instrucțiuni de asamblare (a se vedea pagina 2)

Informații generale pentru o asamblare reușită

Vă rugăm să citiți cu atenție instrucțiunile de asamblare și să respectați măsurile de siguranță. Alocați suficient timp pentru asamblare. Înainte de a începe asamblarea, eliberați o suprafață de aproximativ doi-trei metri pătrați. Scoateți articolul din ambalaj! Așezați toate piesele și toate uneltele necesare astfel încât să fie la îndemână.

- **Vă rugăm să rețineți:** Strângeți ferm toate conexiunile cu șuruburi numai după ce ați terminat asamblarea. În caz contrar, acest lucru poate duce la o tensiune nedorită.

Pasul 1

- Instalați picioarele (8 și 12), bordurile laterale (9), la cuva (6) folosind șuruburi (B) și piulițe (C).
- Instalați suporturile de borduri laterale (10) pe cuva (6) folosind șuruburi (A) și piulițe (C).

Pasul 2

- Instalați bordul inferior (11) la picioarele (8 și 11), folosind șuruburi (A) și piulițe (C).

Pasul 3

- Instalați axul (14) și roțile (13) folosind șaibe (E) și (F) și fixați-le cu piulițe (D).

Pasul 4

- Instalați parbrizele (3)(4)(5) pe cuva, folosind șuruburi (A) și piulițe (C).







Pasul 5

- Instalați grila de coacere (1) pe parbrizele (3)(4)(5).

Pasul 6

- Instalați broșetă (7) la parbrizele.

Lista de piese (a se vedea pagina 2)

Nr.	Descriere	Cant.	Nr.	Descriere	Cant.	Literă	Descriere	Cant.
1	Grilă de coacere	1	8	Picior lung	2	A	Șurub M5x10mm 	19
2	Mânerul grilei	2	9	Bord lateral	2	B	Șurub M5x16mm 	12
3	Parbrizul drept	1	10	Suport pentru bordul lateral	4	C	Piuliță M5 	31
4	Parbrizul din spate	1	11	Bord inferior	1	D	Piuliță de blocare 	2
5	Parbrizul stâng	1	12	Picior pentru roată	2	E	Șaibă de plastic M8 	2
6	Cuva	1	13	Roată	2	F	Șaibă M8 	2
7	Broșetă	1	14	Axa roții	1			

Date tehnice

Dimensiunea grilei de coacere: 49x29 cm

Greutate brută: 7,1 kg

Aprinderea combustibilului

 **AVERTISMENT - risc de ardere!** La aprinderea benzinei sau a rachiului alb se poate dezvolta o căldură incontrollabilă ca urmare a deflagrației. Prin urmare, trebuie să utilizați numai combustibil inofensiv, cum ar fi aprinzătoarele de foc. Grătarul trebuie să fie poziționat pe o suprafață stabilă și sigură atunci când este utilizat.

1. Puneți o parte din cărbuni sau brichete în cuva.
2. Aprindeți unul sau două brichete solide folosind un chibrit lung. Așezați aceste brichete deasupra stratului de cărbuni sau brichete.
3. Lăsați brichetele solide să ardă timp de 2 până la 4 minute. Apoi, umpleți încet cuva cu cărbuni sau brichete.
4. Un strat alb de cenușă ar trebui să se formeze pe combustibil după aproximativ 15-20 de minute. Acest lucru indică faptul că a fost atinsă condiția optimă de prăjire. Distribuți uniform combustibilul în cuva cu ajutorul unei unelte metalice adecvate.
5. Introduceți grătarul uns și apoi puteți începe grătarul.

Curățare / Îngrijire

 **AVERTISMENT - risc de ardere!** Lăsați grătarul să se răcească complet înainte de a-l curăța. Nu utilizați niciodată apă pentru a stinge grătarul încins. Acest lucru ar putea duce la arsuri sau arsuri.

Curățarea ocazională este necesară pentru a păstra aspectul frumos al grătarului. Nu folosiți niciun agent de curățare.

1. O cârpă de clătire și puțină apă cu un detergent comercial sunt suficiente pentru procesul normal de curățare.
2. Dacă piesele emailate sunt foarte murdare, utilizați un agent de curățare a smalțului din comerț (detergent pentru cuptoare). Respectați instrucțiunile producătorului pentru agentul de curățare utilizat.
3. Curățați grătarul folosind lichid de spălat și un tampon de curățare antirugină.

Protecția mediului și eliminarea deșeurilor

Acordați atenție curățeniei atunci când folosiți grătarul și eliminați deșeurile într-un mod curat și sigur. Ca regulă generală, aruncați deșeurile numai în recipientele metalice sau neinflamabile desemnate.

Se aplică reglementările locale pentru eliminare.

* Producătorul își rezervă dreptul de a aduce modificări minore la designul și specificațiile tehnice ale produsului fără notificare prealabilă, cu excepția cazului în care aceste modificări afectează în mod semnificativ performanța și siguranța produselor. Piesele descrise / ilustrate în paginile manualului pe care îl țineți în mâini pot viza și alte modele din linia de produse ale producătorului cu caracteristici similare și pot să nu fie incluse în produsul pe care tocmai l-ați achiziționat.

* Pentru a asigura siguranța și fiabilitatea produsului, precum și valabilitatea garanției, toate lucrările de reparații, inspecții, reparații sau înlocuiri, inclusiv întreținerea și reglajele speciale, trebuie efectuate numai de către tehnicieni ai departamentului de service autorizat al producătorului.

* Utilizați întotdeauna produsul cu echipamentul furnizat. Funcționarea produsului cu echipamente care nu sunt furnizate poate cauza defectuni sau chiar vătămări grave sau chiar moartea. Producătorul și importatorul nu sunt răspunzători pentru vătămările și daunele rezultate din utilizarea unui echipament neconform.

