

Davide e Luigi Volpi S.p.A.
Via San Rocco, 10
46040 CASALROMANO MN
ITALIA



COMPANY WITH QUALITY SYSTEM
MANAGEMENT CERTIFIED BY ICIM
= ISO 9001 =

Potatore a catena cordless con asta
Cordless electronic chainsaw with pole
Schnurlose elektronische Kettensäge mit Stange
Motosierra electrónica sin cable con pértiga
Tronçonneuse électronique sans fil avec perche

KVS7000P – KVS7100P



Manuale d'uso - User Manual – Benutzerhandbuch - Manual del usuario –





WARNING: CAREFULLY READ ALL THE PAGES AND ILLUSTRATIONS BEFORE USING THE TOOL FOR THE FIRST TIME

1. Safety information	30
2. Safety symbols.....	30
3. General safety information for electric tools.....	32
4. Special safety instructions.....	34
5. Intended use	37
6. Description of the features	38
7. Overview of the tool	38
8. List of components	39
9. Technical specifications	42
10. Battery charging.....	42
11. Working environment	43
12. Initial assembly	43
13. Early working procedures.....	45
14. Instructions for cutting.....	46
15. Cleaning and maintenance.....	47
16. Storage	52
17. Disposal	53
18. Spare parts	53
19. Warranty	53
20. Troubleshooting	54
21. Declaration of conformity.....	56

1. Safety information



Before using the machine for the first time, carefully read this instruction manual for your own safety and for the safety of others. Keep this manual in a safe place and make it available to any new owners to ensure the information here reported is always available.

2. Safety symbols

This section includes the safety indications for the use of this machine.

2.1. Symbols in the manual



Danger symbol



Risk of severing or serious injury



Hot surface



Instructions symbol



Carefully read the instruction manual



Wear protective gloves



Wear protective glasses



Wear protective shoes with non-slip sole



Do not use the tool in case of rain or on wet branches



Do not dispose of in household waste



Chain movement direction



Guaranteed sound power level according to Directive 2000/14/EC in dB(A) to make noise emissions comparable between products.

2.2. Symbols on the battery



Li-ion Li-ion battery, do not dispose of in household waste



Do not expose the battery to fire, it can explode



Do not disassemble the battery



Battery can be recharged and recycled. Used batteries must be collected with respect for the environment.

2.3. Symbols on the battery charger



Danger indication



Use the battery charger indoor only



Safety temperature limiter



Isolation class II



Electrical equipment, do not throw away
with household waste

3. General safety information for electric tools



Warning ! Carefully read these safety instructions !

Failure to follow the safety instructions can result in electric shock and / or serious injury.

Keep all safety instructions for future use.

The term “power tool” used in the safety instructions refers to corded tools connected to the electrical distribution and to cordless tools.

3.1. Safety of the work area

- Keep the work area clean and well lit. Untidy and dark work areas can cause accidents.
- Do not use the power tool in flammable or explosive atmospheres, such as in the presence of flammable liquids, gases or dusts. The electric tool can generate sparks that can ignite flammable dust or fumes.
- Keep children and passersby away while using the power tool, distractions can cause you to lose control of the tool.

3.2. Electric safety for the battery charger

- The plug of the charger must match the power outlet. Do not modify the socket. Do not modify the plug for any reason. Do not use adapters if the tool plug has a ground connection. Proper use of unmodified plugs with compatible sockets reduces the risk of electric shock.
- Avoid body contact with earthed surfaces such as pipes, radiators, coolers. There is a greater risk of electric shock if your body comes into contact with objects that discharge to the ground
- Do not expose the instrument to rain or humid conditions. Any water entering the charger can create a risk of electric shock.
- Do not mishandle the cable. Do not use the cable to move, pull or disconnect the charger.
- Keep the cable away from sources of heat, oil, sharp edges and moving parts. A damaged or tangled cord can increase the risk of electric shock.
- If the charger is used outdoors, use an extension cable suitable for outdoor use. The use of a suitable cable reduces the risk of electric shock.
- If it is not possible to avoid using the charger in a humid area, use a power supply with an RCD differential switch. The use of a differential switch reduces the risk of electric shock.

3.3. Warnings for the use of tools

- People using a chainsaw for the first time must first perform the necessary cutting exercises on a tripod.
- The chainsaw may bounce if it encounters an object that is too hard or if the bar suddenly jams or stops.
- When the bar is used for cutting from top to bottom, the tension direction of the chainsaw is opposite to that of the operator.

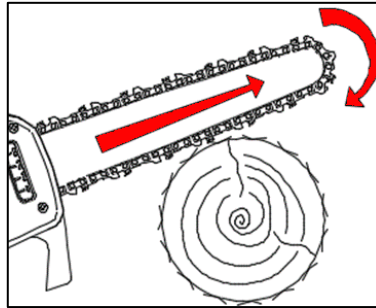

- When the guide plate is used for a bottom-up cut, the pushing direction of the chainsaw is towards the operator.

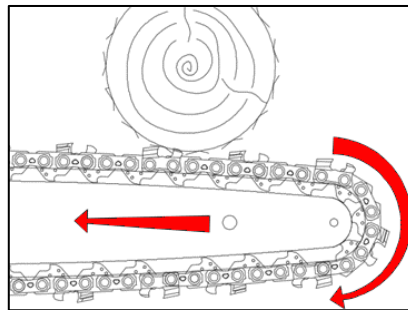

- Hold the saw firmly with one hand on the control handle area so that the thumb wraps around the control handle.
- Do not overload the tool, selecting a suitable tool for the purpose makes work safer and more efficient
- Do not use the tool if the switch does not work properly. The tool must be repaired if the switch does not work properly.
- Disconnect the battery from the tool before making adjustments, repairs and before putting the tool away. This will reduce the risk of inadvertent tool implementation.
- Keep the tool away from children, do not allow people who are not trained to use the tool to use it
- Perform tool maintenance. Check the tool and moving parts, damaged components can cause accidents and injuries. Proper maintenance of the tool can reduce the risk of accidents.
- Keep the chain clean and regularly oiled. This makes the tool more controllable and reduces the risk of tool locking.
- Read the manual before using the tool, select the tool and accessories correctly to avoid accidents.

3.4. Warnings for the use of the battery-powered tools

- Use only the charger specified by the manufacturer. The use of battery chargers can damage the battery and cause risk of fire and explosion.
- The tool is designed for use with the original battery only. The use of different batteries can damage the tool and increase the risk of injury.
- The battery should be stored away from metal parts (such as coins, paper clips, nails, screws). A short circuit can cause a fire.
- The incorrect use can cause leakage from the battery. In case of contact with the liquid, wash thoroughly with water and consult a doctor. Liquid leaking from the battery can cause injury and burns.

3.5. Personal Safety

- While using the tool, stay focused, do not distract, use common sense. Do not use the tool if you are too tired or under the influence of medicines, drugs, alcohol or other substances. A moment of inattention can result in serious personal injury.
- Use the personal protective equipment indicated in this manual to reduce the risk of personal injury (gloves, glasses, visor, appropriate shoes or boots, helmet).



Use gloves complying with EN 388. Performance Level LP=5

WARNING: Many types of wire-mesh gloves are suitable only for use with sharp tools moved by human strength (knives, scissors, hatchets); with motorized band saws there is the risk of entanglement in the teeth of the band saw blade dragged with force and speed by the motor and, therefore, serious injury to the hand; their use is therefore prohibited.

- Carrying the tool with your finger on the trigger can cause hazard of accidental operation.
- Remove all repair keys and tools before turning on the switch. A key connected to moving parts can cause personal injury.
- Don't get unbalanced. Maintain the correct balance of the body in every situation. This allows a better control of the tool in case of unexpected situations.
- Use with appropriate clothing. Do not use with loose clothing or jewelry. Keep clothes, gloves and hair away from moving parts to prevent them from getting entangled.

4. Special safety instructions

4.1. Special safety instructions for chainsaw

- Keep passers-by and other people at a minimum safety distance of 1.5m, do not move the tool while the chain is moving. Careful use of the tool can avoid injury.
- Handle the tool only when the chain is stopped. Protect the chain during storage to reduce the risk of injury.
- Hold the rear handle of the pruner with one hand and hold the pole firmly with the other,
- otherwise the risk of personal injury may be greater.

- Take up the chainsaw only as described.
- Wear safety glasses and hearing protection. Additional protective equipments for the head, hands, legs and feet are recommended. Full protective clothing will reduce personal injury from flying debris or accidental contact with the chain.
- Ensure to stand firmly and on a safe and plain surface before switching on the chainsaw. Slippery or unstable surfaces, such as stairs, can cause the chainsaw to lose balance or control.
- Be careful that thin materials could jam the chain when cutting shrubs or small trees and could hit the operator.
- Do not use the chainsaw for different purposes than that for which it is intended. For example, do not use your chainsaw to cut plastic, stone, or non-wood building materials. The use of the chainsaw for different purposes than the intended involves risks for the operator.
- During a cut, if the head of the bar touches an object and crushes the chain, bouncing can occur.
- Do not rely solely on the safety equipment fitted to the chainsaw.
- A variety of measures must be taken to prevent accidents or personal injury during operations.
- To avoid sudden bounces, hold the chainsaw firmly. Adjust body and arms position to avoid bouncing. The operator can control the rebound force if following the necessary precautions.
- Do not extend your arms too much while cutting.
- Use only replacement bars and chains specified by the manufacturer. Improper replacement of bars or chains can cause the chain to break and / or rebound.

4.2. Altre istruzioni di sicurezza



Use appropriate clothing, use protective shoes with non-slip soles.



Use protective glasses



Use protective gloves LP=5

- Do not wear loose clothing or jewelry that could get tangled in moving parts.
- Pay attention, do not get distracted, use common sense when using the tool. Do not use the tool if excessively tired or under the influence of drugs, drugs, alcohol or other substances.
- Do not use the chainsaw in rainy weather.
- The tool is designed for pruning branches, do not use on hard wood or other objects.
- Do not try to unlock the chain if the tool is blocked before turning off the tool.
- Before starting pruning, check that there are not hidden objects and cables between the branches.
- During use, firmly grab the tool with both hands.
- Do not use the tool near flammable liquids or gases to avoid the risk of fire or explosion.
- The wear of the chain must be checked regularly. Damages resulting from use with a chain and / or bar in poor condition are not covered by the warranty.
- Do not try to repair the tool yourself, always bring the tool to service centers in case of need for repairs.

All repair and maintenance operations not described in this manual must be carried out by the service center.

4.3. . Special safety instructions for battery-powered tools

- The charger is designed for indoor use. Charging operations must be made indoor.
- Remove the battery before cleaning the charger to avoid damages and the risk of electric shock.
- Do not expose the battery to the sun or bright light. Do not place it into contact with hot surfaces. It could cause the battery to explode.
- Allow the battery to cool completely before starting charging.
- Do not disassemble or damage the battery to avoid personal injury

4.4. Correct use of the battery charger

- Use the battery charger only with rechargeable batteries. Otherwise it could cause fire and explosions. Use only the original battery charger.
- Always check the charger, the cable and the plug before each use. If damaged, ask to the service center for repair or replacement. Do not use damaged chargers. Do not try to repair damaged battery chargers to keep the tool safe.
- Check that the voltage of the charger matches the one of the battery, otherwise it may cause personal injury.
- Keep the charger clean, away from humid environments and rain. Do not use the charger outdoors: dirt and water may cause damages to the charger and personal injury.
- The charger is designed for use with original batteries, otherwise it may cause risk of fire or explosions.
- Do not use damaged chargers to reduce the risk of injury.
- Do not use the charger on flammable surfaces (eg. paper).
- The battery is not fully charged on first use, it must be charged for 3/4 hours before first use.
- The normal charging time is 3/4 hours (charging time for 2 fully discharged batteries), do not charge the battery for too long to avoid damaging it.
- The charger has three outputs, it is possible to charge up to 3 batteries at the same time. The charging time is proportional to the number of batteries connected and to the state of their charge. Supervise the charging time by the LED indicator (red light in charge, green light end of charge).

4.5. Attention (Residual risks)

Use the tool carefully in order to avoid the following risks:

- Cuts and wounds caused by sharp edges
- Use for prolonged times or in incorrect positions can cause damage to your body in the long term.



Warning!

The device can produce electromagnetic waves and interfere with electro-medical devices. It is recommended to consult a doctor before using this tool with electro-medical devices.



Warning!

Do not touch the chain when the battery is on the tool.

Keep passers-by and other people at a minimum distance of 1.5m



Warning!

In particular situations, the chain and the handle could reach high temperatures. It is recommended to handle the tool with care using protective gloves.

Noise measurements:



Calculation of the measured and guaranteed sound power level was carried out according to the procedure in Directive 2000/14/EC, Annex V.

Measured sound power level: 92 dB(A)

Guaranteed sound power level: 94 dB(A)

4.6. Tool safety requirements

The chainsaw is safe if it meets the following requirements:

1. The chain is not damaged
2. The chain tension is correct
3. The bar is not deformed
4. The bar slot is intact
5. The chainsaw is clean and dry
6. The handle is intact
7. The locking ring nut of the extension is correctly tightened
8. Head locking ring nut is correctly tightened
9. Lubrication works properly
10. The depth of the slot of the tooth between the wheel and chain does not exceed 0.5mm
11. Bar and chain are assembled correctly as specified in this manual
12. Any accessories used are conform and original
13. The oil cap is closed correctly

5. Intended use

The tool is designed for pruning branches only.

A different use than indicated can damage the tool and cause dangers.

The tool is designed for adult use only, do not use in rainy weather or to work on wet plants or bushes.

The manufacturer is not responsible for damages caused by the non-observance of the instructions in this manual.



Check the correct tension and sharpening of the chain before using the tool.

Damages caused by the use of an not sharpened and / or incorrectly tensioned chain are not covered by the warranty.

6. Description of the features

The tool is suitable for pruning branches and cutting small diameter trees. It is recommended to comply with the warnings contained in this user manual.

In case of danger or malfunction release the trigger, the chain will stop to prevent damage or injuries.

7. Overview of the tool

- | | |
|-----------------------------------|-----------------------------------|
| 1) Chain | 12) Handle |
| 2) Bar | 13) Hand protection |
| 3) Oil tank | 14) Switch-on trigger |
| 4) Chain oil cap | 15) Safety trigger |
| 5) Engine crankcase | 16) Battery housing |
| 6) Pinion housing | 17) Display |
| 7) Lock nut | 18) Lubrication adjustment button |
| 8) Chain tension adjustment screw | 19) Power button |
| 9) Hook | 20) Battery |
| 10) Pole adjustment ring nut | 21) Three-way battery charger |
| 11) Pole adjustment counter ring | |

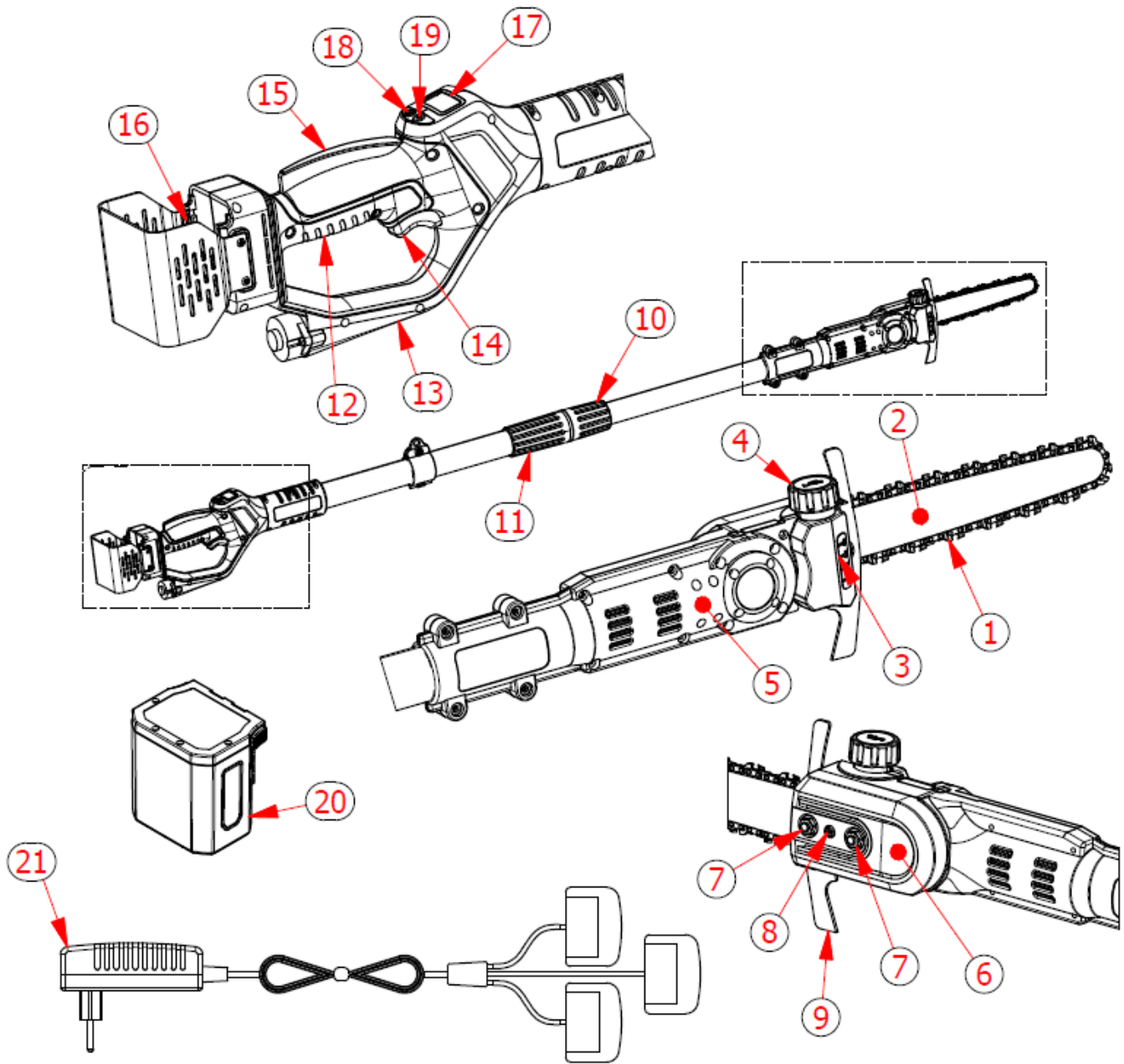

8. List of components

Open the packaging carefully and check all the components listed below:

- Electronic chainsaw with pole
- 2 Batteries
- Battery charger
- Toolbox
- chain oil bottle
- user's manual









8.1. Display



Displayed nr	Description
1	On-off switch
2	Chain oil adjustment switch and working time display
3	S = partial working time - T = total working time
4	Working time indicator
5	10% - 20% = Quantity of oil per cycle
6	01Hz – 02Hz – 03Hz = pumpings for second
7	Electronic board temperature indicator
8	Battery charge indicator
9	Battery charge percentage

8.2. Display functions and settings

Description of display and functions of chainsaw				
N°	Description	Icon	Content	Function
1	Battery status display			Non-modifiable
2	Working time display		Display settings	Press the button until the clock icon flashes and press the button to adjust from partial working time (S) to total working time (T).

3	Oil quantity display		Oil quantity settings	<p>1. Quantity oil settings: press the button  until the number before “HZ” flashes and press the button  to select the oil quantity that is necessary.</p> <p>2. Flow rate settings: press the button  until the nr before “%” flashes and press the button  to select the flow rate that is necessary.</p> <p>3. Forced lubrication: press the button  for 3 seconds to start the forced lubrication and the icon  starts flashing. Press the button  for 3 seconds to stop the lubrication.</p>
4	Electronic board temperature display	°C	Degrees centigrade	Non modifiable

8.3. Error codes and descriptions

Displayed code	Error description		Cause	Solution
E1	Chain rotation locking	The red-light flashes	Overextended chain or motor/ reducer locking	Check chain tension or contact service center
E2	Hardware over-voltage		Excessive force during work or driver failure	Adjust the force or contact service center
E3	Circuit failure		Driver failure	Contact a service center
E4	Incorrect voltage		Driver failure	Contact a service center
E5	Undervoltage		Low Battery	Charge the battery
E6	Overvoltage		Battery failure	Substitute the battery
E7	Overvoltage softwere		Activated protection	Automatic reset
E8	Phase loss		Motor failure or cable failure	Contact a service center
E9	Low battery capacity		Battery failure	Substitute the battery
E13	Oil pump failure		Oil pump failure	Contact a service center
E15	Overtemperature MOS		Driver protection	Automatic reset

Note: if the problem is not clear, always contact with a service center.

9. Technical specifications

Electronic chainsaw with lithium battery		
1	Maximum cutting dimensions	160 mm
2	Chain speed	7,5 m/s
3	Bar lenght	19,0 cm – 8"
4	Chain	1/4 x 1,1 - 48 links
5	Chain tension adjustment	Manual
6	Lubrication	Automatic and adjustable
7	Display visualisation	See chapter 7.1
8	Motor	Brushless
9	Rated voltage	DC 21,6V
10	Rated power	950 W
11	Chainsaw Dimensions	170 / 250 x 13 x 10 cm - KVS7000P 250 / 350 x 13 x 10 cm - KVS7100P
12	Weight without battery	2,7 kg – KVS7000P 3,0 kg – KVS7100P
13	Weight with battery	3,2 kg – KVS7000P 3,5 kg – KVS7100P
Battery (lithium-ion)		
1	Capacity	4,0 Ah
2	Tension	21,6V
3	Power	86,4 Wh
4	Battery weight	0,5kg
Caricabatteria		
1	Supply voltage	100-240V AC ,50-60Hz
2	Output voltage	DC21V
3	Charging current	1,4A
4	Protection class	II
5	Charging time	4 h

10. Battery charging



Do not expose the battery to extreme conditions such as excessive temperatures or shocks. Injury can be caused by the loss of battery material.



Disconnect the battery from the tool before start charging.



Make sure the battery is dry and clean before start charging.

- Make sure the battery is fully charged before using it for the first time.
- The battery is not fully charged when purchased, charge it for 3-4 hours before using it for the first time.
- Before charging the battery, check the remaining charge on the display.
- The battery must be replaced if its life start being insufficient. Use only the original batteries supplied by the manufacturer.
- Respect the safety and environmental protection guidelines during each phase.

10.1. Battery charging procedure

- Recharge indoor, temperature between + 10 ° C and 45 ° C.
- The three-way battery charger allows to recharge the two batteries supplied at the same time.
- Make sure that the characteristics of the charger and the battery are aligned before starting the recharge.
- The red LED on the charger indicates that the battery is charging, the green LED indicates that it is fully charged. The approximate charging time is 3 to 4 hours (charging time for 2 fully discharged batteries at the same time), do not keep the batteries connected longer than necessary as they may be damaged.
- The charger has three ways, it is possible to charge up to 3 batteries at the same time. The charging time is proportional to the number of batteries connected and to the state of their charge. Monitor the charging time by the LED indicator (red light in charge, green light end of charge).
- Disconnect the battery charger connectors from the batteries once the charge is complete.
- Make sure the battery is charged at least every 4 months when not in use. Do not store the machine with the battery connected.

11. Working environment

- Keep the temperature between 10 ° C and 45 ° C during the charging phase and between 0 ° C and 45 ° C during use.
- Keep the tool temperature between 0 ° C and 60 ° C during use.
- Do not use it in an explosive environment or near flammable materials or liquids.
- Do not use it in rainy weather or on wet branches.

12. Initial assembly

- Assemble bar and chain as follows
- Unscrew the two nuts
- Remove the two nuts and the pinion housing.
- Position the chain on the bar by correctly inserting the teeth into the bar groove.
- Unscrew the central chain tension adjustment screw

- Attach the chain to the pinion and position the bar - **WARNING - MAKE SURE THE CHAIN ADJUSTMENT PEG IS CORRECTLY INSERTED INTO THE BAR HOLE**
- Replace the pinion housing and screw on the two nuts without tightening them.
- Tighten the central chain tension adjustment screw and check that the tension is correct.
- Using protective gloves, pull the chain downwards and check that the chain guide links are still visible at half height at the bottom of the bar.
- If the guide links are fully visible when pulling down the chain, or if they are not visible at all, the tension is not correct - repeat the adjustment.
- Tighten the two nuts and check the chain tension again.

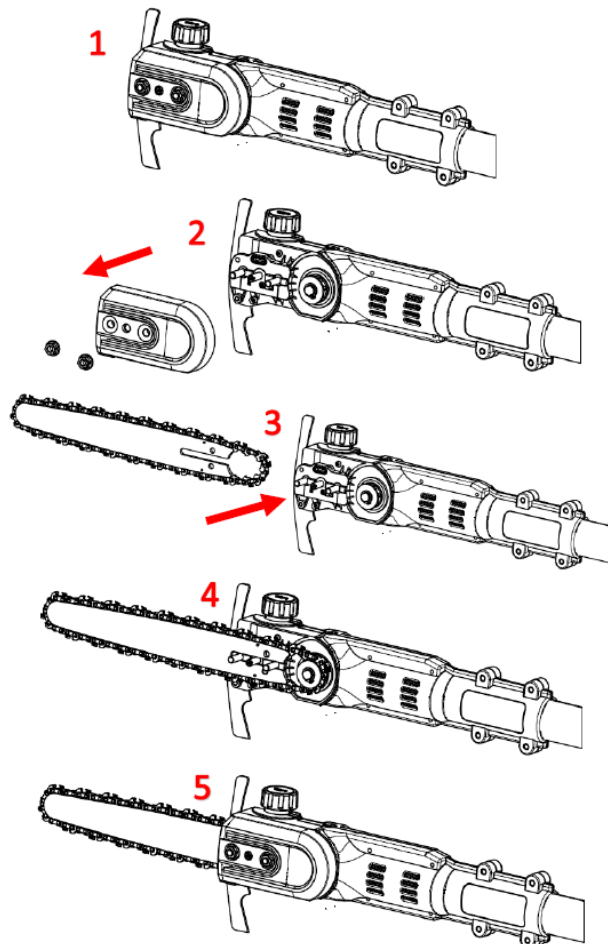

- Fill the oil tank as specified in paragraph 14.5
- Insert the battery into the special location of the chainsaw until it clicks, checking that it is locked.

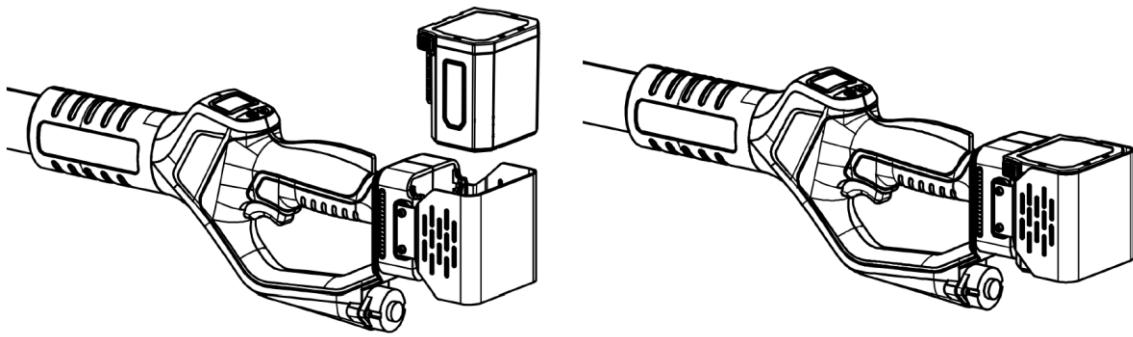

- To adjust the length of the pole, loosen the adjustment ring nut
- Pull out the extension to the desired size and hold it in place
- Tighten the pole adjustment ring nut until it is locked.

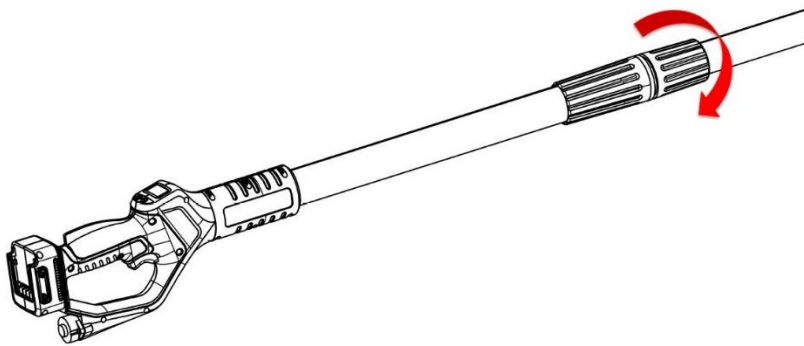

13. Early working procedures



Wear suitable gloves and clothing before using this tool. Check the tool before working and verify the correct operation of the switch. The chain must stop when the trigger is released. Do not use the chainsaw if the switch fails. Check that the battery voltage matches the tool voltage.



The engine stops when the trigger is released, but the chain will continue moving by inertia for a few seconds. Do not touch the chain while it is moving to avoid the risk of injury or wounds.



WHEN USING THE TOOL FOR THE FIRST TIME AND EACH TIME THE CHAIN IS CHANGED, RUN THE CHAIN FOR A FEW SECONDS WITHOUT CUTTING. CHECK CHAIN TENSION AND, IF NECESSARY, ADJUST THE TENSION TO AVOID RISK OF INJURY

- Hold the chainsaw firmly with both hands.
- Make sure that the chain and bar are not in contact with any object.
- Press the safety button to unlock the trigger.
- Press the trigger all the way down, the machine starts.
- Do not exceed the cutting dimensions to protect the chainsaw and battery from possible damages.
- Do not cut branches larger than those indicated in the technical specifications.
- Release the trigger if the chain is blocked, the engine stops.

Warning: in case of a blocked chain, before intervening, release the trigger and remove the battery.

14. Instructions for cutting



Use appropriate clothing, use protective shoes with non-slip soles.



Use protective gloves



Use protective glasses



Danger of cutting and serious injury



Warning!

In particular situations, the chain and handle could reach high temperatures. It is recommended to handle the chainsaw with care using protective gloves.

Warning!

If the branch to be cut is under tension, the bar could get stuck and the user will lose control of the chainsaw, resulting in serious injury.

Therefore, first of all make a lightning cut (1) on the pressure side (A), then a cross-cutting cut (2) on the pulling side (B).

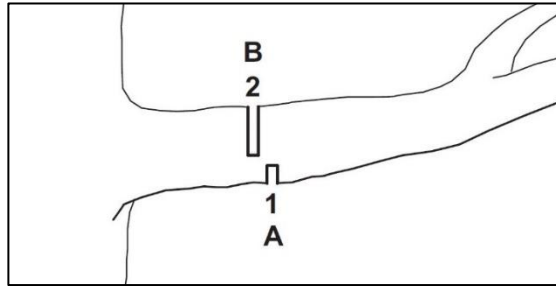

- Always keep the chainsaw at full speed.
- Do not cut using the end of the bar.
- Constantly check that the lubrication is working correctly.
- While moving the chainsaw from one branch to another, release the trigger to stop the chain.
- Keep passers-by and other people at a minimum distance of 1.5m.
- Do not use the tool in the rain or in humid environments.
- After use, remove the battery from the chainsaw.
- If left unused for 10 minutes, the chainsaw switches off automatically.

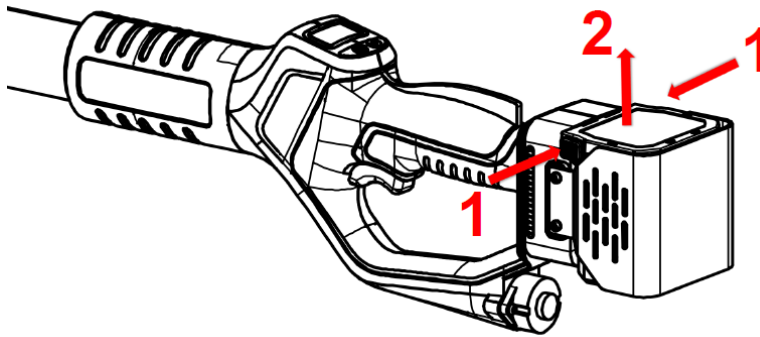

Warning: in case of difficult cut, check the battery charge and the correct sharpening and tension of the chain.

15.Cleaning and maintenance



Tools to be repaired should be brought to the service center. The use of original parts will ensure the correct and safe operation of the tool.



Disconnect the battery from the tool before checking, doing maintenance, repairing or cleaning the tool to avoid the danger of accidental tool activation.



Warning!

In particular situations, the chain and handle could reach high temperatures. It is recommended to handle the chainsaw with care using protective gloves.



Wear protective gloves before carrying out operations on the chain.

Warning!

Before any maintenance or cleaning operations, remove the battery from the chainsaw. Accidental starting can cause serious injury.

Frequent checks of the tool will make it safe and reliable.

- Keep the handle, any motor ventilation devices clean, use a cloth to clean the tool. Do not use detergents to clean the tool to avoid damaging the surfaces.
- Clean the body of the chainsaw with a damp cloth.
- Remove the protective pinion cover.
- Clean the area around the pinion and the body with a damp cloth.
- Remove the bar and the chain as specified in paragraph 14.2
- Clean the oil outlet (1), oil inlet (2) and rear bar slot (3) with a soft brush.

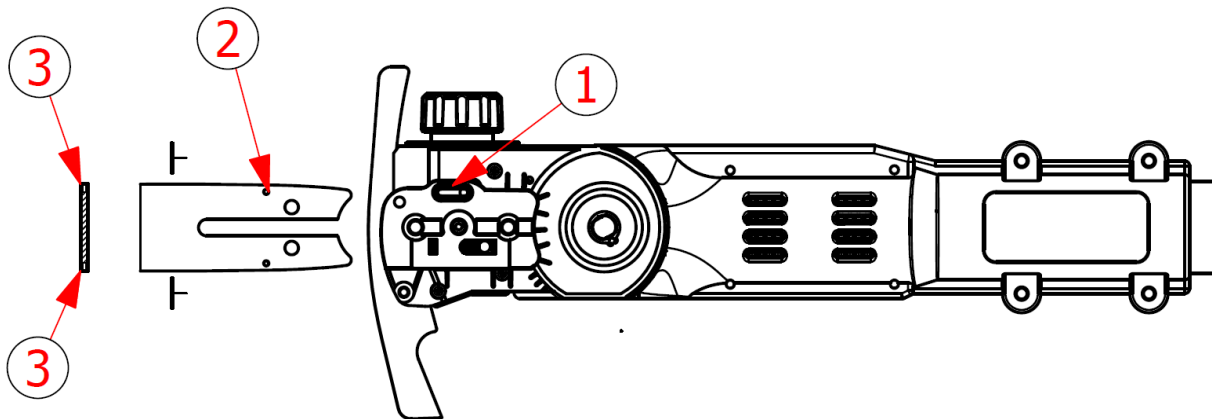

- Clean the chain with a soft brush.
- Assemble again the bar, the chain and the cover as specified in paragraph 14.3

15.1. Maintenance

General maintenance, cleaning, lubrication and the replacement of the chain and / or bar require disassembly and assembly of the chainsaw.

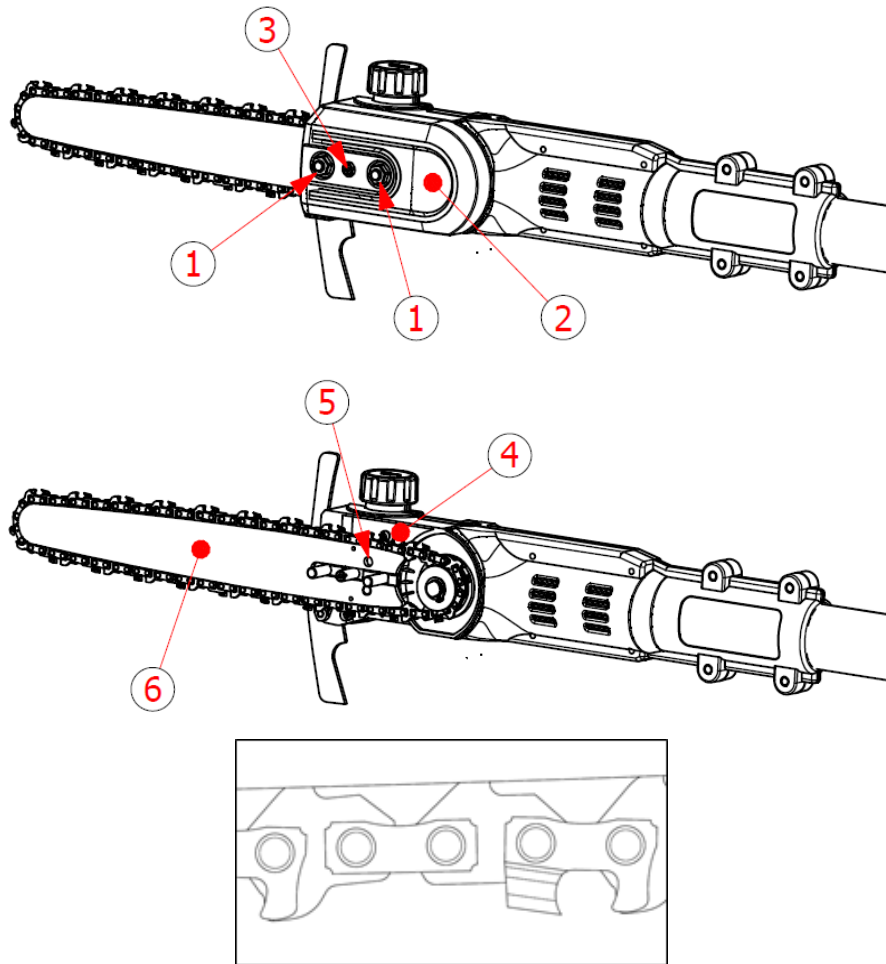

15.2. Chain and bar disassembly

- Disconnect the battery from the chainsaw.
- Use the Allen wrench supplied to unscrew the two locking nuts ① and remove the cover ②.
- Unscrew anti-clockwise the chain tension adjusting screw ③ to loosen the tension.
- Remove the chain and bar.

15.3. Chain and bar assembly

- Disconnect the battery from the chainsaw.
- Adjust the tension adjustment screw ③, place the bar on the chainsaw body ④ and insert the guide plate fixing column ⑤ into the fixing hole on the bar.
- Insert the chain onto the sprocket and into the bar groove so that the arrows on the chain joining links face the top in the direction of movement.
- Assemble the pinion cover and tighten the two locking nuts ①.

15.4. Chain tension

While using the chainsaw, the chain overheats and could stretch. If necessary, adjust the chain tension as indicated below.

- Disconnect the battery from the chainsaw.

- Use the Allen wrench supplied to slightly loosen the two locking nuts ①.
- Screw (to increase the tension) or unscrew (to decrease the tension) the chain tension adjustment screw ③.
- By helping you with the protective gloves, pull the chain down and check that the guide links of the chain are still visible for half the height in the lower part of the bar.

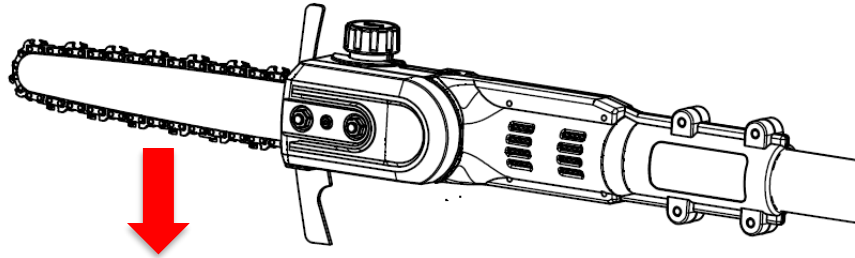

- If the guide links are fully visible when pulling the chain down, or if they are not visible at all, it means that the tension is incorrect.
- Repeat the adjustment.
- Tighten the two locknuts ①.

Warning!

The chain pinion must not be disassembled by the user, but by at a specialized service center. If the chain pinion is damaged, do not use the chainsaw and take it to a specialized service center.

15.5. Chain Lubrication

The chainsaw is equipped with an automatic oil pump that allows to keep the chain lubricated and cooled. To fill the oil tank, follow the instructions.

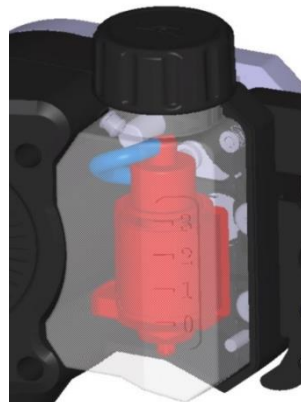

- Disconnect the battery from the chainsaw.
- Place the chainsaw in a horizontal position with the oil cap facing upwards.
- Clean the oil cap, the tank and the surrounding environment with a damp cloth.
- Unscrew the oil cap and remove it.
- Fill the tank to the appropriate level and prevent it from overflowing.
- Use **UNIVERSAL BIODEGRADABLE FLUID FOR CHAINSAWS BARS AND CHAINS**
- Firmly screw the oil cap.

Warning!

The chain lubrication is adjustable (see chapter 7.2).

The set values are the optimal ones for the correct operation of the chainsaw.

To check the correct operation of the oil pump, turn on the chainsaw and check if there are traces of oil on the ground below.

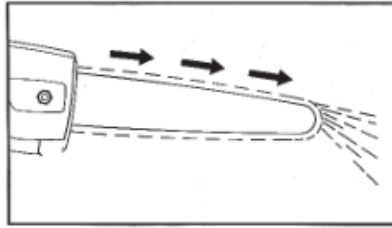

If there are not traces of oil, check to have refilled the tank.

If there are not traces of oil with the tank full, contact the service center.

Warning!

Do not use the chainsaw if the oil pump is not working properly.

15.6. Lubrificazione riduttore

To guarantee the correct operation and durability of the chainsaw, it is necessary to add grease to the gearbox each 20 hrs of work.

Clean the cap, the tank and the surrounding environment with a damp cloth.

Loosen the screw indicated by the arrow and add 5-10 g of grease.

Tighten the screw completely.

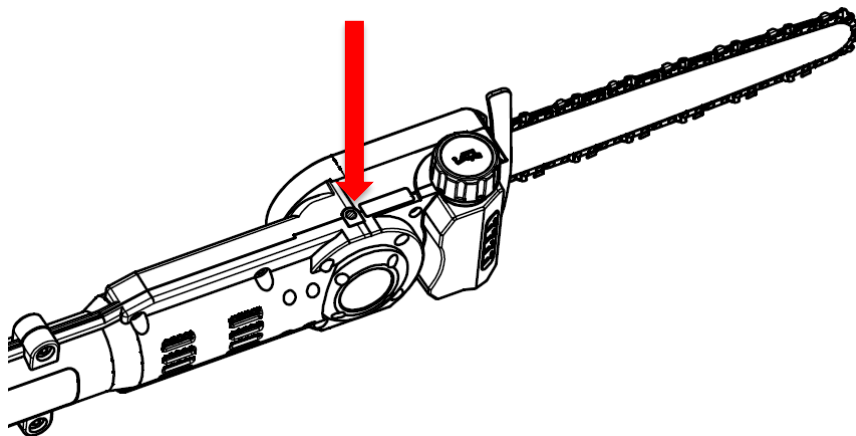

USE "VOLPI ORIGINALE" SPRAY GREASE TO ENSURE DURABILITY AND RELIABILITY FOR YOUR TOOLS

Ask for it to your local dealer.

15.7. Pinion and bar inspection

- Disconnect the battery from the chainsaw.
- Use the Allen key supplied to unscrew the two locking nuts ① and remove the cover ②.
- Remove the chain and the bar.
- Measure the depth of the chain groove using a depth gauge.
- If the depth of the groove exceeds 0.5 mm, do not use the chainsaw and contact the service center to replace the pinion of the chain.
- Measure the depth of the pinion of the chain slot using a depth gauge.
- If the depth is less than 1.1mm, if the bar is damaged or the slot is deformed, replace the bar to avoid damaging the chain and the chainsaw.

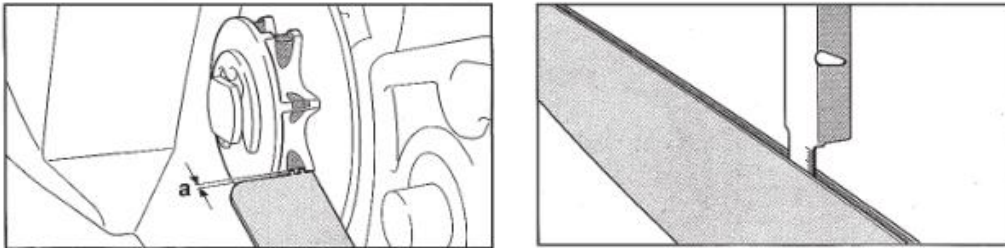

16.Storage

The most important thing to keep in mind before storing your chainsaw is the lithium-ion battery. Make sure that the batteries are fully charged.

If storing the battery for a long time with low charge will damage the battery and invalidate the warranty.

- 1) Make sure the battery is fully charged.
- 2) Avoid storing the device in extremely hot or cold environments.
- 3) If the device will not be used for a long time, please remove the battery before storing it.
- 4) Batteries and chargers should be placed in a safe place to prevent the entry of heat, dust and humidity.
- 5) Batteries should be stored in a dry environment.

Suggested storage temperatures:

less than 1 month	-20°C ~ +60°C
Less than 6 months	-10°C ~ +35°C
More than 6 months	0°C ~ +30°C

- The battery must be kept at a distance of at least 1.5m from possible flammable substances.
- For good battery maintenance, fully charge it before storage. Charge at least once per 4 months during long periods of disuse.

17. Disposal

- Remove the battery from the tool; dispose the battery, the tool, the accessories and the packaging according to the type of material.



-  Do not dispose the tool with household waste
- Take the tool to a waste collection center. Metal and plastic parts can be recycled. For more detailed information contact the service center.



- **LI-ION** Do not dispose the battery in household waste, do not burn, do not immerse in water. In case of gas or liquid leakage, the battery can cause damage to the environment and health.
- Before disposing the battery, discharge it completely. It is recommended to cover the poles with adhesive tape to prevent short circuits. Do not disassemble the battery.
- Dispose the batteries in accordance with local regulations. The battery must be taken to a waste collection center and disposed in an environmental- friendly way. For detailed information consult your local waste disposal offices or our service center.
- Dispose the pruned branches in the designated bins. Do not dispose them with household waste.

18. Spare parts

The manufacturer can supply high quality original spare parts:

- Batteries
- Battery chargers
- Chains

Contact us in case of need.

19. Warranty

The warranty covers 24 months for private users and 12 months for professional users. The warranty covers mechanical parts, including battery, charger, motor and transmission mechanism. The warranty is not valid in the following cases:

- Wrong use of the tool
- Maintenance not performed as indicated in this user manual
- Modifications made on the tool
- Tool damages even if caused by mistake
- Damages caused by reparations operated by unqualified people
- Natural events
- Lack of the battery charge with the required frequency

- Components subject to wear during normal use (eg chain, bar) are excluded from the warranty.

The warranty is valid only for products that have been registered through the website within 30 days of the date of purchase.

For more information you can write to

info@volpioriginale.it

Activate the warranty of your new electronic tool through our website:

<https://www.volpioriginale.it/registra-il-tuo-prodotto/>



The buyer must also keep a copy of the sales document (receipt, invoice) and of the warranty registration: a copy of these documents has to be delivered to the Dealer or Authorized Repairer together with the machine to be repaired. In the absence of these documents, the machine will be considered in any case out of warranty.

20.Troubleshooting

Make sure that the tool is repaired only by qualified people from our service centers, using only original parts as spare parts.

This will ensure the life and the safety of the tool.

Problem	Possible cause	Corrective action
La chainsaw does not work	Low battery	Charge the battery
	Battery disconnected	Connect the battery
	Switch malfunction	Send to the service center
Intermittent operation	Loose internal connections	Send to the service center
	Switch malfunction	

Chain heated	Ruined chain	Replace the chain
	Poor lubrication	Check the lubrication
	Damaged bar	Replace the bar
Bad cutting surface	There is no lubrication, resulting in excessive friction	Check the lubrication
	Ruined chain	Replace the chain
	The cut result is poor	Read carefully the user's manual
	The battery is not fully charged	Charge the battery
It does not charge. Red light of the charger flashes	The battery is not inserted correctly in the battery charger connector	Insert the connector correctly
	The charger is not properly connected to the power socket	Connect it properly
	Dirty battery poles	Clean the poles
	Damaged battery	Replace the battery
	Damaged Battery charger	Replace the battery charger

21. Declaration of conformity

CE DECLARATION OF CONFORMITY

2023		
DICHIARAZIONE DI CONFORMITÀ UE <i>EU Declaration of Conformity</i>		
Apparecchio <i>Appliance</i>	Potatore ad asta a batteria e suo pacco batteria <i>Pole-mounted battery powered pruner and its detachable battery pack</i>	
	Modello KVS7000P <i>Model</i> KVS7100P	Modello pacco batteria KVS2000R70 <i>Battery pack model</i>
Costruttore <i>Manufacturer</i>	Davide e Luigi VOLPI S.p.A. Via S. Rocco, 10 46040 Casalromano (MN)	
LA PRESENTE DICHIARAZIONE DI CONFORMITÀ È RILASCIATA SOTTO LA RESPONSABILITÀ ESCLUSIVA DEL FABBRICANTE <i>THIS DECLARATION OF CONFORMITY IS ISSUED UNDER THE SOLE RESPONSIBILITY OF THE MANUFACTURER</i>		
Oggetto della Dichiarazione: Potatore ad asta a batteria mod. KVS7000P e KVS7100P con elemento di taglio costituito da sega a catena di potenza nominale 0,950 kW alimentata a 21,6 V dal suo pacco batteria staccabile KVS2000R70 Object of Declaration: Pole-mounted battery powered pruner mod. KVS7000P and KVS7100P with cutting attachment consisting of a saw-chain power supplied at 21,6 V by its detachable battery pack KVS2000R70 with rated power 0,950 kW		
 		
L'OGGETTO DELLA DICHIARAZIONE DI CUI SOPRA È CONFORME ALLA PERTINENTE NORMATIVA DI ARMONIZZAZIONE DELL'UNIONE: <i>THE OBJECT OF THE DECLARATION DESCRIBED ABOVE IS IN CONFORMITY WITH THE RELEVANT UNION HARMONISATION LEGISLATION:</i>		
Direttiva Macchine 2006/42/CE - Machinery Directive 2006/42/EC Direttiva EMC 2014/30/UE - EMC Directive 2014/30/EU Direttiva ROHS 2011/65/EU - ROHS Directive 2011/65/EU		
Con riferimento alle seguenti Norme armonizzate: <i>With reference to the following Harmonized standards:</i>		
EN 62841-1:2015/AC:2015 + Allegato K "Battery tools and battery pack"	EN ISO 5349-2:2001 + A1:2015 EN ISO 20643:2008 + A1:2012 EN 62233:2008 + AC:2008	IEC 62321-3-1:2013 IEC 62321-4:2013 + A1:2017 IEC 62321-5:2013
EN ISO 12100:2010 EN 3744:2010/EN 3744:1995 EN ISO 354:2003 EN 12096:1997 EN ISO 5349-1:2001	EN 55014-1:2017 + A11:2020 EN 55014-2:2015 EN 63000:2018 IEC 62321-1:2013	IEC 62321-6:2015 IEC 62321-7-1:2015 IEC 62321-7-2:2017 IEC 62321-8:2017
Data - Date 28/03/2023	Luogo - Place Casalromano (MN) - Italy	Firma Legale - Legal Signature  Signatura Identificativa Volpi Original S.p.A. - 00136560208 46100 CASALROMANO (MN) Cod. Fisc. e P.IVA: 00136560208
Davide e Luigi Volpi S.p.A. Via S. Rocco, 10 - 46040 Casalromano (MN)	P. IVA 00136560208 REA: 00136560208	www.volpioriginale.it



Davide e Luigi Volpi S.p.A.

Via San Rocco, 10 – 46040 Casalromano (MN) Italy
www.volpioriginale.it - info@volpioriginale.it

YLBKVS7000P_4-Libretto d'uso ITA_ENG _GER_ESP_FR

