

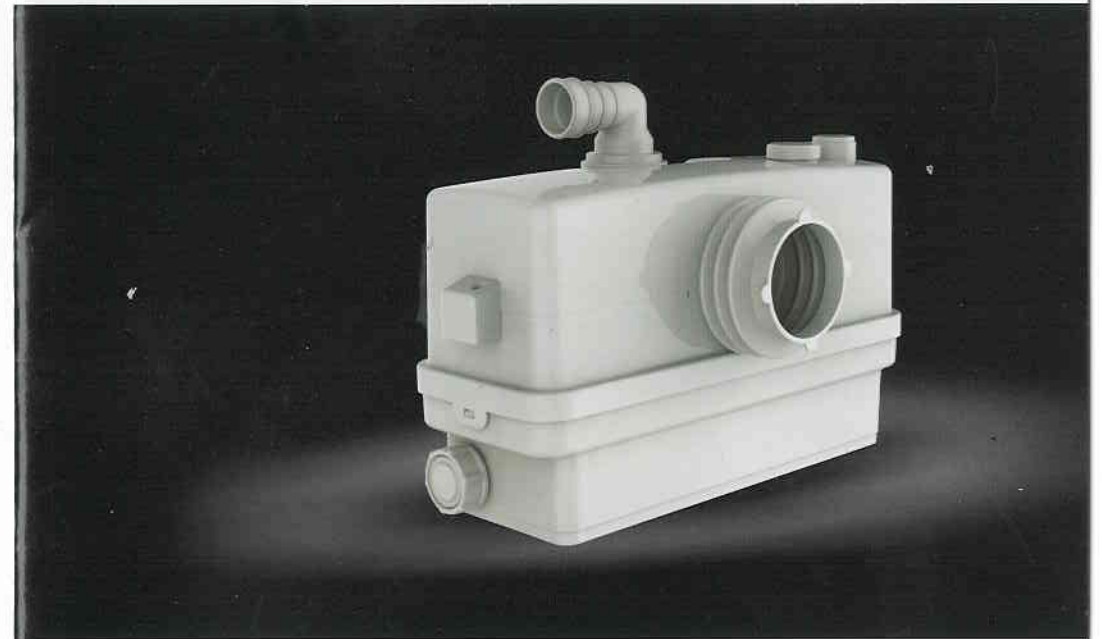

B.①
≡ INNOVATION ≡



DOMESTIC LIFTING STATION

www.leogroup.cn

WC601

LEO GROUP PUMP(ZHEJIANG) CO.,LTD.

CONTENTS

1. General description	3
2. Technical data	3
3. Safety instructions	3
4. Product sizes	4
5. Installation instructions	5
6. Function of control panel	8
7. Maintenance	8
8. Function of control panel	8
9. Troubleshooting	9

This appliance can be used by children aged from 8 years and above and persons with reduced physical, sensory or mental capabilities or lack of experience and knowledge if they have been given supervision or instruction concerning use of the appliance in a safe way and understand the hazards involved.

Children shall not play with the appliance. Cleaning and user maintenance shall not be made by children without supervision.

This appliance supplied through a residual current device(RCD) having a rated residual operating current not exceeding 30mA.

Attention!

If the appliance or the supply cord is damaged, it must be repaired by manufacturer, its service agent or qualified person.



Meaning of crossed –out wheeled dustbin:

Do not dispose of electrical appliances as unsorted municipal waste, use separate collection facilities.

Contact you local government for information regarding the collection systems available.



Prior to installation, read these instructions.

1. General description

The Wc601 series is an automatic lifting station suitable for pumping domestic wastewater and sewage off places in private dwellings such as a cabinet, a washbasin or a toilet, where wastewater cannot be led directly to the sewer by means of a natural downward slope.

2. Technical data

Supply voltage: 220~240V/50Hz
 Input power: 600 W
 Speed: 2800 rpm
 Rated current: 3 A
 Insulation class: F
 Protection class: IP 44
 Max flow: 6.5 m³/h
 Max head: 8.5 m
 Supply cable: 1.6m, 0.75mm² (H05VV-F-3G)
 Net weight: 7.7 kgs
 Start level: 90 mm above bottom
 Stop level: 40 mm above bottom
 Max liquid temperature: 50°C
 Ambient temperature: +0°C to +35°C
 Duty: S3-50% - 1min.(30 sec.on; 30 sec.off)

3. Safety instructions

- 1). To ensure a normal and safe work of this product, please read this manual carefully before operation.
- 2). The product must be reliably earthed. For safety reason, installation of a leakage protection switch is required. Do not leave the plug wet when plugged in. Do not place the socket in wet locations.
- 3). Before carrying out any service work, switch off the power supply.
- 4). Power shall be supplied in accordance with the voltage and frequency marked on nameplate.

4. Product sizes

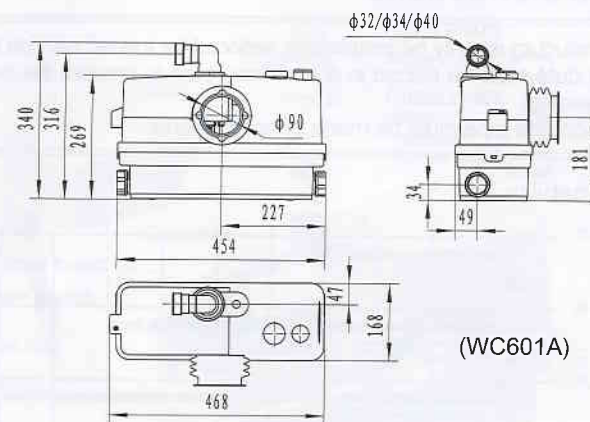

(WC601A)

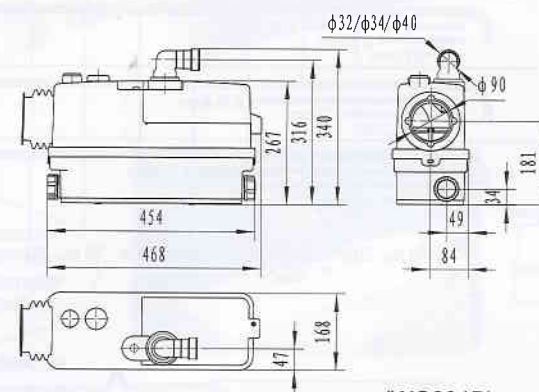

(WC601B)

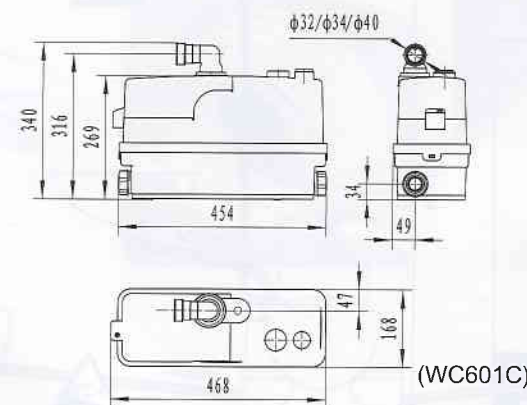

(WC601C)

5. Installation instructions



The product must only be installed or serviced by trained service personnel.
The product must be placed in a frost-free room to prevent the pumped liquid from freezing.
The discharge pipe must be made of rigid material.

1). Delivery capability

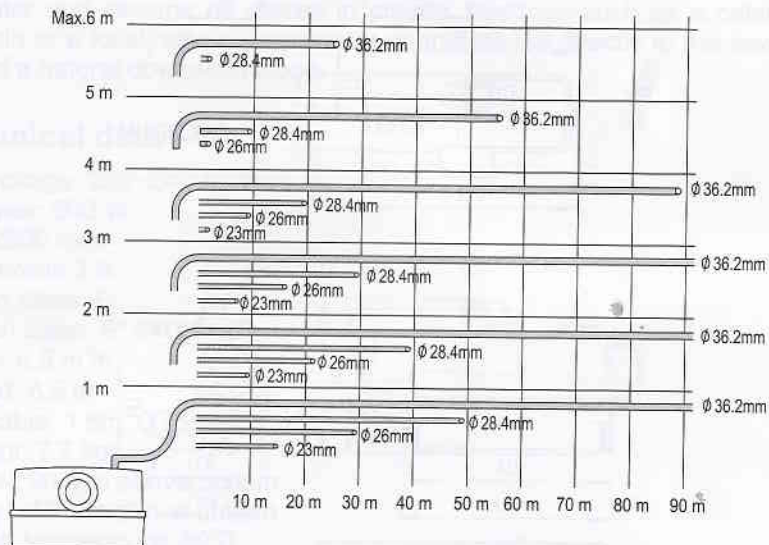

2). Installation

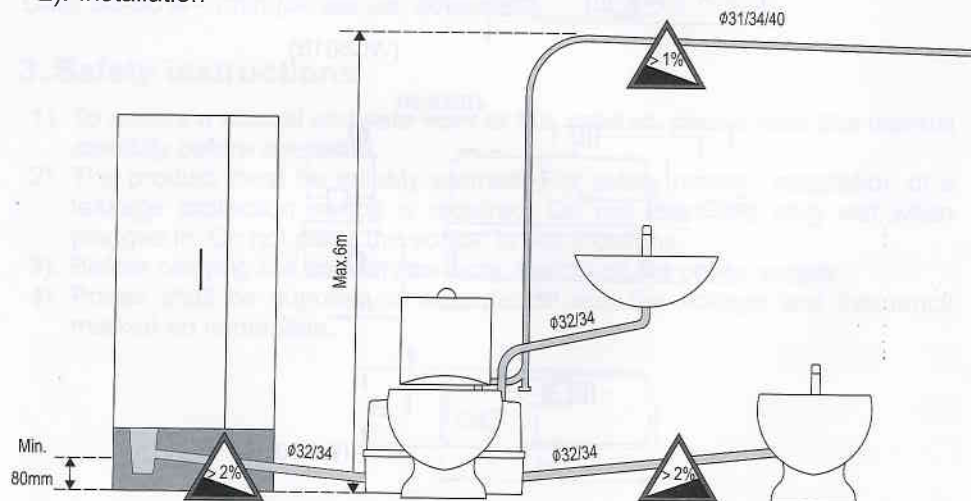

4. Function of control panel

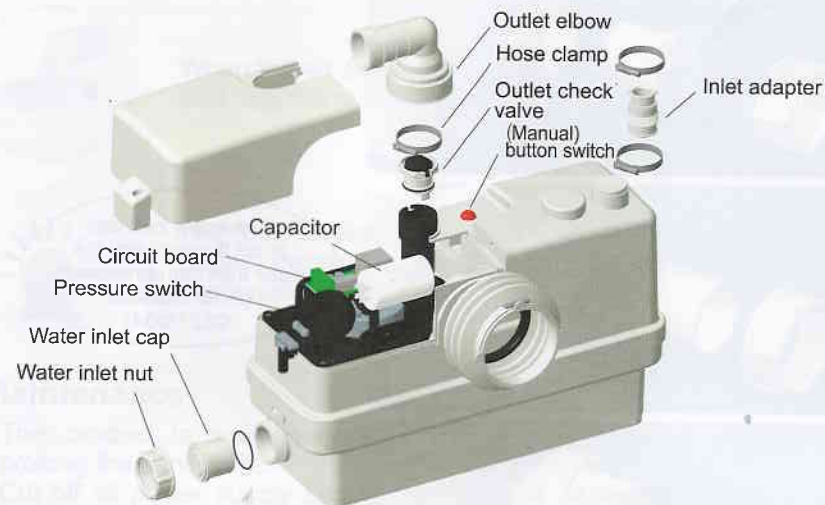

NO.1 360° rotatable water elbow, with hose clamp. (Inner diameter $\phi 32 / \phi 34 / \phi 40$)



The inlet is fastened by a hose clamp. (Inner diameter $\phi 90$)

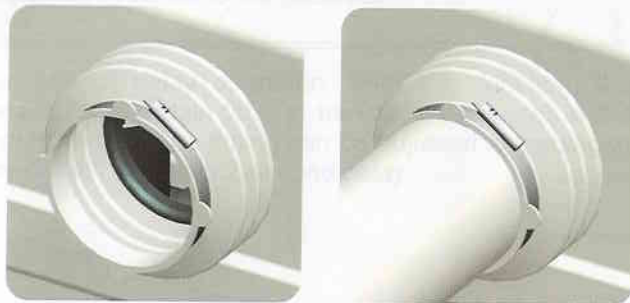

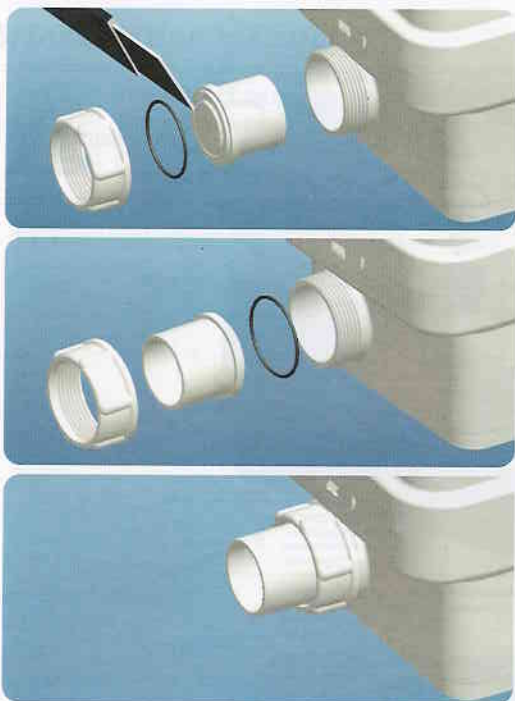

The water inlet cap is cut through, and the water inlet cap is reversed. (Inner diameter $\Phi 32 / \Phi 34$)

6. Function of control panel



When the air switch fails to drain water automatically, press and hold the manual drain switch to drain water.



With buzzer alarm, stall alarm function. When the alarm is issued, the plug should be unplugged, and the fault can be continued before use.

7. Maintenance

- 1). This product is maintenance-free. However, the correct operation will prolong the service life.
- 2). Cut off all power supply before maintenance. Make sure that the power supply cannot be accidentally switched on. Never do the maintenance by yourself. All maintenance for motor and electrical parts must be carried out by qualified personnel.
- 3). In case of no use for a long time, it is recommended to flush the machine with clean water twice and power it off.
- 4). The carbon filter should be replaced once a year.

8. Function of control panel



The timer must only be set by trained service personnel.

This product has the function of delay operation. With this function, the machine continues to operate for a certain time to transfer wastewater in the pipe after the machine is switched off. The timing can be adjusted according to the pipe length. The factory default setting is 2-second delay.

9. Troubleshooting

	Check the pump after power cut-off.
--	--

Fault	Cause	Remedy
Motor does not start when the level in the tank reaches the start level.	Supply failure.	Check the power supply.
	Fuse blown. If new fuse blows at once, either cable or motor is faulty.	Replace the fuse. Measure cable and motor. If cable or motor is defective, replace the defective parts.
	Impeller/Cutter is clogged. Thermal switch tripped.	Clean the impeller/Cutter. Wait until the motor is cooled down and the thermal switch has reset.
	Pressure switch pipe blocked.	Remove the pressure switch and clean the pipe.
Motor hums but does not operate.	Impeller/Cutter is clogged.	Clean the impeller/Cutter and check if it rotates properly.
	Motor or capacitor defective.	Replace the motor or capacitor.
	Control board defective.	Replace the control board.
Motor runs continuously or at irregular intervals.	Water leaking from inlet into tank.	Check for leaking appliances.
	Water leaking back into tank from discharge pipe.	Check the non-return flap.
	Pressure switch defective.	Replace the pressure switch unit.
Motor runs but does not evacuate water.	Pump blocked.	Remove blockage.
	Air lock in pump or vent hole in pump housing blocked.	Check operation of valve in the tank. Check that the carbon filter is not wet. Check that the vent hole in the pump housing is not blocked.
Motor runs but does not evacuate water.	Discharge port or pipe blocked.	Remove blockage. Check the non-return flap.
The lifting station evacuates slowly.	The pressure switch or cutter is clogged.	Check and clean the pressure switch and cutter.
	Discharge pipe is too long or has an excessive number of bends.	Increase discharge pipe size. Change pipework to reduce number of bends. Change bends to swept bends.
	The pump housing is leaky.	Replace the pump housing.

Fault	Cause	Remedy
Rattling noise from the lifting station, but water is evacuated.	Foreign body on impeller/Cutter.	Remove the foreign body.
Odour from the tank.	Carbon filter contaminated.	Replace the carbon filter.
Backflow from the lifting station.	Non-return flap in inlet stuck, does not open or does not close sufficiently.	Check the non-return flap.
	The pressure switch or cutter is clogged.	Check and clean the pressure switch and cutter.
	The start level has changed.	Check and clean the pressure switch pipe.