



[www.husqvarna.com](http://www.husqvarna.com)



## Parts Manual

Z 242F / 96766570100

Please read the operator manual carefully and make sure you understand the instructions before using the machine.

Gasoline containing a maximum of 10% ethanol (E10) is permitted for use in this machine. The use of gasoline with more than 10% ethanol (E10) will void the product warranty.

2019-03-25

115 88 29-28 Rev. C



When you need spare parts or support in service questions, warranty issues, etc., please consult the following professional:

This manual belongs to the machine with the manufacturing number:	Engine	Transmission

Ref.	Part No.	Qty	Description	Kit / Assy Includes
1	587 59 56-01	1	Decal, Steer / Brake Left	
2	587 59 55-01	1	Decal, Steer / Brake Right	
3	587 76 92-01	2	Decal, Z 242F	
4	539 10 57-45	1	Decal, Battery Warning	
5	532 42 86-77	1	Decal, Crown	
6	539 10 83-85	1	Decal, Do Not Tow	
7	539 10 83-86	1	Decal, Exit Mower	
8	539 10 98-97	1	Decal, Service	
9	590 48 55-01	1	Decal, Safety Warnings	
10	532 42 38-29	1	Decal, Responsibility	
11	588 03 51-01	1	Decal, Start	
12	586 97 88-01	1	Decal, Deflector	
13	577 46 90-01	2	Decal, Husqvarna	
14	510 24 02-01	1	Decal, Belt Routing	
15	589 35 79-01	1	Decal, No Step	
16	501 08 26-01	1	Decal, ECM Australia	
17	581 72 41-02	1	Decal, 80 DBA	
18	593 36 30-01	1	Decal, Emissions	
19	590 88 49-01	1	Decal, ClearCut™	
20	587 00 07-01	1	Pad, Abrasive	

**Manufacturing Number**

The machine's manufacturing number can be found on the printed plate affixed to the engine compartment.

Stated on the plate, from the top are:

- The machine's type designation (I.D.).
- The manufacturer's type number (Model).
- The machine's serial number (Serial no.)

*Please have the type designation and serial number available when ordering spare parts.*

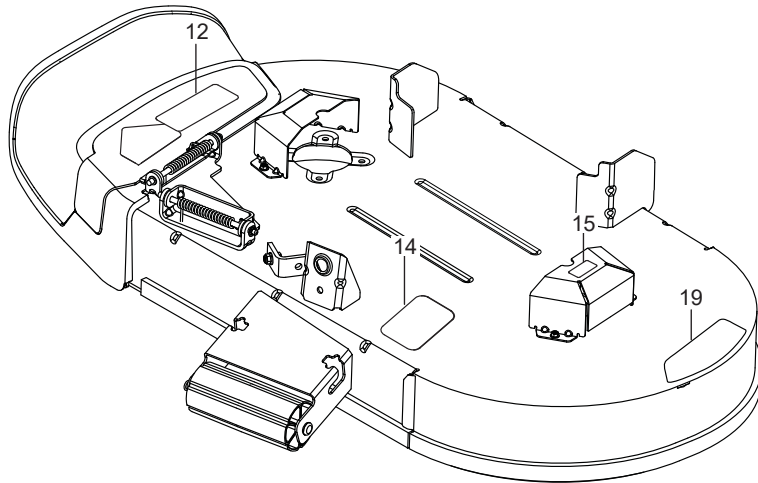
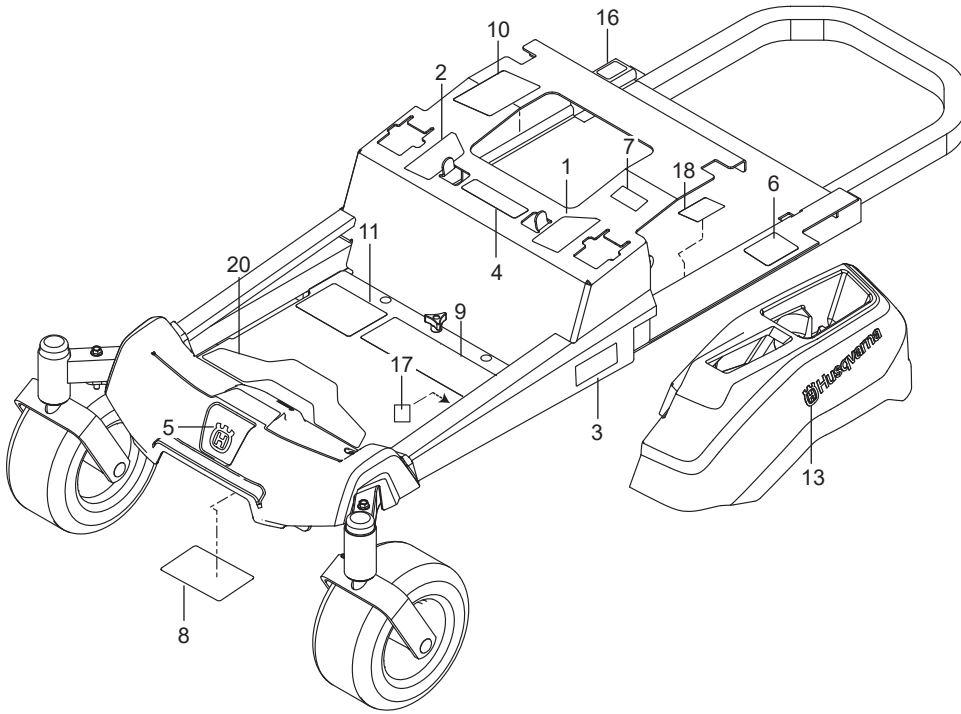

FRAME .....4

ENGINE MOUNTING, GUARDS & MUFFLER .....6

STEERING .....8

IGNITION SYSTEM.....10

BRAKE / LIFT .....12

HYDRAULIC PUMP-MOTOR..... 14

WHEELS & TIRES .....16

MOWER DECK / CUTTING DECK .....18

SEAT .....20

DECALS .....22

Illustrations may or may not represent the actual assemblies and it is not recommended to use this manual as a guide to assemble or disassemble the mower.

NOTE: All fasteners are Grade 5 unless otherwise specified.

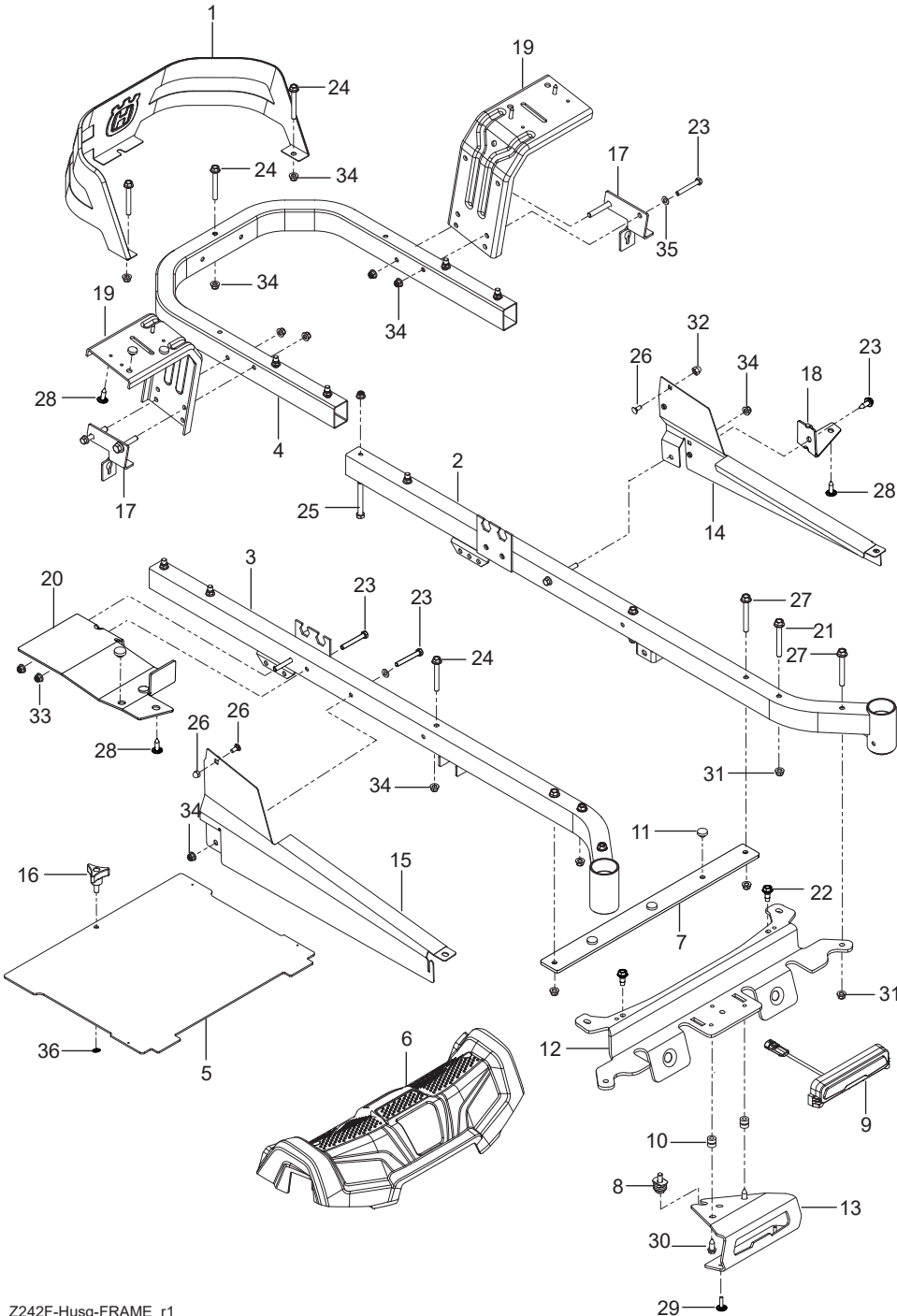

Ref.	Part No.	Qty	Description	Kit / Assy Includes
1	532 43 98-22	1	Seat, Grey	
	588 61 42-02	1	Armrest Assembly Right	
	588 61 42-01	1	Armrest Assembly Left	
2	587 23 20-02	1	Pan, Seat	
3	586 22 08-02	1	Plate, Lift Support	
4	586 22 12-02	1	Plate, Deck Lift	
5	589 76 12-06	1	Support, Seat Org	
6	580 30 82-02	2	Support, Seat Rear Blk	
7	532 19 82-00	1	Spring, Latch	
8	589 48 35-01	2	Spring, Seat	
9	532 40 15-45	1	Switch, Seat	
10	532 19 76-61	1	Handle, Slide	
11	586 42 86-01	1	Leg, Support	
12	585 98 93-01	2	Grommet, Bumper	
13	539 10 47-63	5	Retainer, U Type	
14	872 14 05-06	4	Bolt 5/16-18 x 3/4 Rd Head Sq Neck	
15	510 42 27-01	2	Bolt 5/16-18 x 2-1/2 Rd Head Sq Neck	
16	874 78 06-20	2	Bolt 3/8-16 x 1-1/4	
17	874 76 06-12	1	Bolt 3/8-16 x 3/4	
18	539 11 03-03	2	Bolt 5/16-18 Shoulder	
19	817 49 05-12	4	Screw 5/16-18 x 3/4 Thread Form	
20	817 00 05-10	6	Screw 5/16-18 x 5/8 Washer Head	
21	539 11 28-99	4	Nut 5/16-18 Hex Flange Nyloc	
22	521 99 65-01	2	Nut 3/8-16 Hex Flange Nyloc	
23	819 14 16-14	2	Washer 3/8 Std Flat	
24	501 05 18-01	1	Washer, Winged	

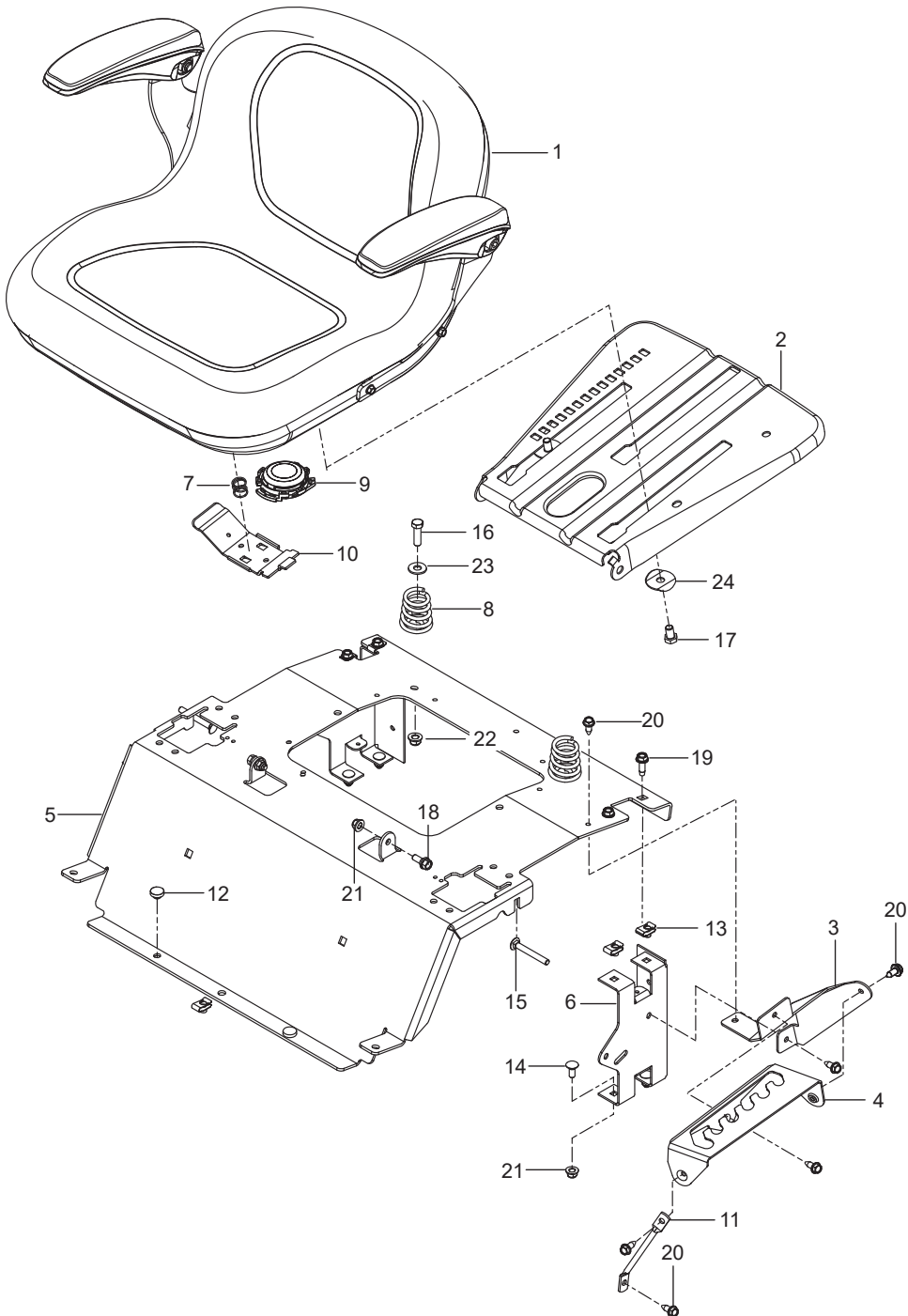

Ref.	Part No.	Qty	Description	Kit / Assy Includes
1	585 03 98-02	1	Guard, Rear Blk	
2	589 28 34-02	1	Frame, Front Right Org	
3	589 28 33-02	1	Frame, Front Left Org	
4	584 99 10-02	1	Frame, Rear Tube Org	
5	522 84 29-02	1	Foot Plate w/ Safety Decal	
6	586 70 38-01	1	Cover, Footrest w/Decal	
7	585 52 30-04	1	Support, Footrest	
8	587 54 69-01	1	Assembly, Isolator Tap	
9	585 91 67-01	1	Assembly, Led Light	
10	587 22 52-01	2	Grommet, Push	
11	585 98 93-01	7	Grommet, Bumper	
12	585 52 31-04	1	Cross Member	
13	587 45 86-02	1	Bracket, Light	
14	585 33 16-02	1	Cover, Rail Right	
15	585 33 15-02	1	Cover, Rail Left	
16	539 10 44-11	1	Knob w/ Stud	
17	585 47 43-02	2	Bracket, Bypass Rod	
18	585 52 36-04	1	Support, Console Left	
19	580 50 13-02	2	Support, Fender Blk	
20	585 52 34-04	1	Support, Console Right	
21	586 65 43-01	2	Bolt 3/8-16 x 3 Shoulder	
22	586 88 11-01	2	Bolt 5/16-18 Shoulder	
23	874 78 05-36	7	Bolt 5/16-18 x 2-1/4	
24	874 78 05-44	5	Bolt 5/16-18 x 2-3/4	
25	874 78 06-48	8	Bolt 3/8-16 x 3	
26	585 94 00-01	2	Bolt 5/16-18 x 1 Carriage	
27	577 11 77-01	4	Bolt 3/8-16 x 3	
28	532 41 63-58	6	Screw #10-24 x 3/4 Hex Head	
29	532 42 17-56	2	Screw #10 x 1/2	
30	817 58 05-20	2	Screw 5/16-18 x 1-1/4 Washer Head	
31	521 99 65-01	8	Nut 3/8-16 Hex Flange Nyloc	
32	585 93 81-01	2	Nut 5/16-18 Acorn	
33	873 90 05-00	2	Nut 5/16-18 Hex Flange Lock	
34	539 11 28-99	9	Nut 5/16-18 Hex Flange Nyloc	
35	819 11 11-16	6	Washer 5/16 SAE Flat	
36	532 42 30-63	1	Palnut 5/16"	

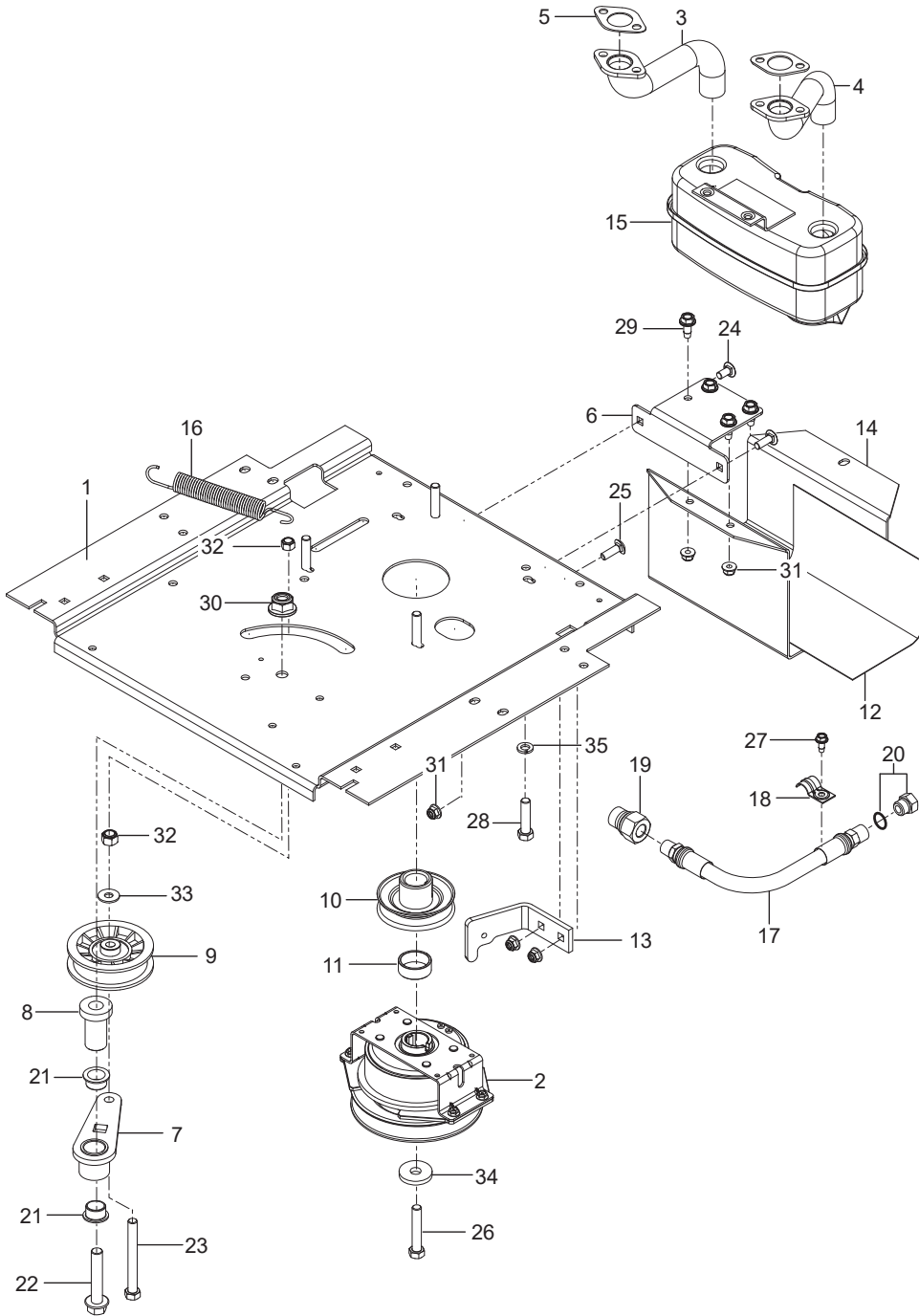

Ref.	Part No.	Qty	Description	Kit / Assy Includes
1	501 06 34-01	1	Deck Org	
2	586 91 81-01	2	Blade, Bagging	
3	587 27 00-01	1	Belt	
4	532 19 61-06	1	Pulley, Idler	
5	532 19 61-04	1	Pulley, Idler	
6	532 19 97-91	2	Pulley, Mandrel	
7	586 87 40-02	1	Arm, Clutch Blk	
8	587 14 05-02	2	Arm, Suspension Blk	
9	586 93 68-05	2	Cover, Belt Gry	
10	587 30 57-01	1	Assy, Deflector Org	
11	532 19 84-68	1	Keeper, Belt	
12	588 61 09-02	1	Link, Front	
13	532 41 55-98	1	Port, Washout	
14	532 13 14-91	2	Rod, Hinge	
15	532 17 91-27	1	Rod, Nose Roller	
16	586 91 80-02	1	Bracket, Hinge Org	
17	532 17 60-66	1	Roller, Nose	
18	532 19 52-63	3	Bushing, Pivot	
19	532 19 51-61	2	Stud w/ Anti-Rotate	
20	539 11 21-70	2	Mandrel, Assembly Aluminum	21, 22
21	532 11 04-85	2	Bearing, Ball	
22	532 18 72-91	2	Shaft, Mandrel	
23	587 35 47-01	2	Spring, Deflector	
24	532 19 72-51	1	Spring, Drive	
25	532 19 42-08	1	Pin, Bowtie Cotter	
26	582 68 32-01	1	Bumper w/Decal	
27	582 36 05-01	2	Bushing	
28	532 11 04-52	2	Push Nut	
29	539 12 81-01	1	Bolt 3/8-16 x 2-1/2 RHSN	
30	872 11 05-05	3	Bolt 5/16-18-5/8 RHSN	
31	532 19 30-03	2	Bolt/Washer 7/16-20	
32	532 19 65-39	2	Bolt, Shoulder	
33	539 11 55-74	1	Eyebolt 5/16 x 3-1/2	
34	532 17 01-65	2	Bolt 5/16-18 Flange Hd	
35	588 43 83-01	1	Screw 7/16-14 x 2-1/8 Hex Hd	
36	584 95 39-01	8	Screw 5/16-18 x 1 Thread Roll	
37	532 13 77-29	4	Screw 1/4-20 x 5/8 Thread Roll	
38	532 40 02-34	2	Nut 9/16 Top Center Lock	
39	539 99 05-85	1	Nut 5/16-18 Hex Whiz Lock	
40	873 36 07-00	1	Nut 7/16-20 Hex Jam	
41	532 17 59-94	1	Nut 7/16-20 Lift Link	
42	873 90 06-00	1	Nut 3/8-16 Flange Lock	
43	873 90 05-00	7	Nut 5/16-18 Hex Flange Lock	
44	539 11 91-24	2	Nut 7/16-14 Hex Nyloc	
45	873 68 06-00	1	Nut 3/8-16 Crown Lock	
46	539 11 28-99	1	Nut 5/16-18 Hex Flange Nyloc	
47	532 18 76-90	2	Washer, Spacer	
48	532 17 85-15	1	Washer, Flat Hardened	

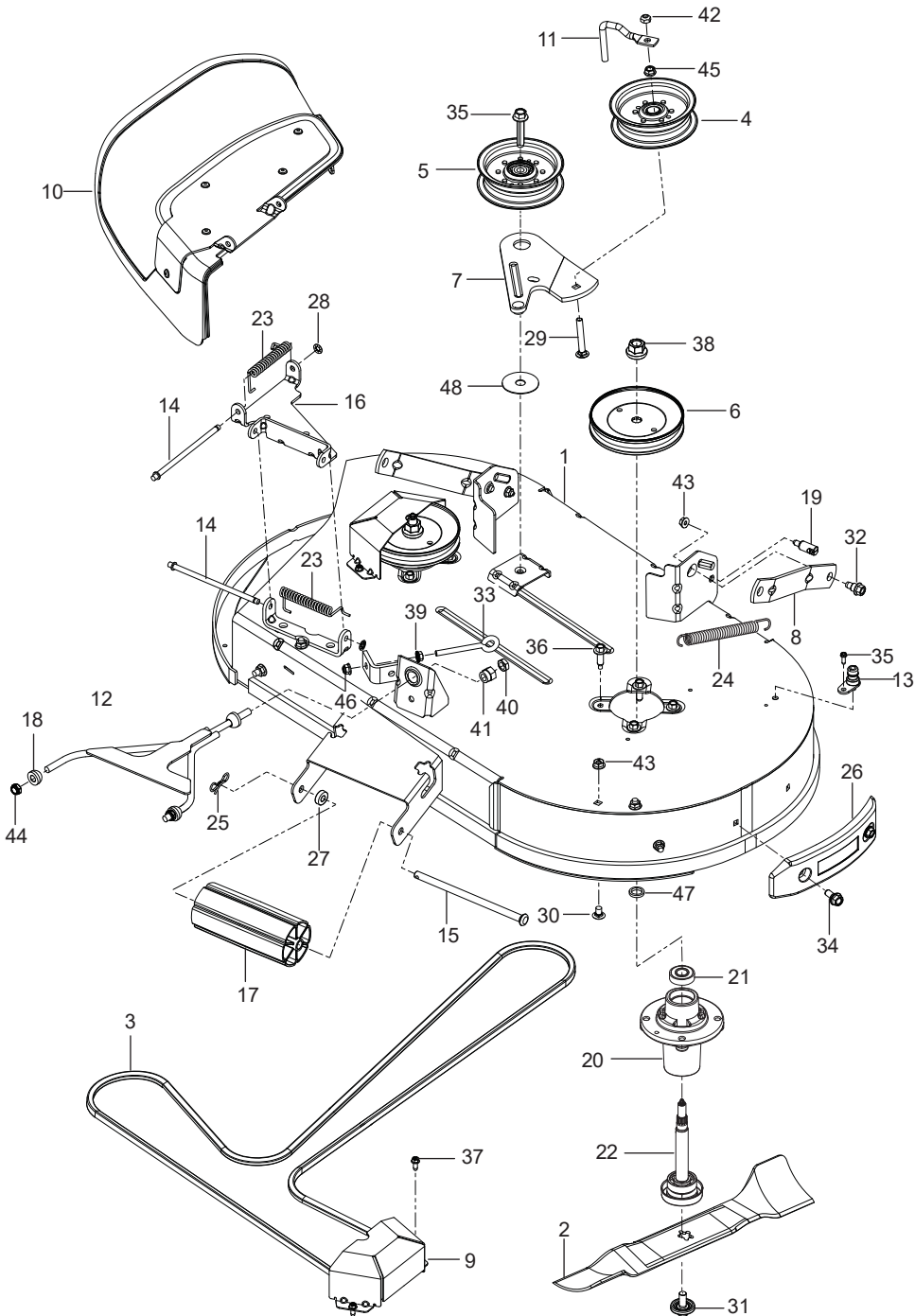

Ref.	Part No.	Qty	Description	Kit / Assy Includes
1	588 01 71-02	1	Plate, Engine Blk	
2	587 24 16-01	1	Clutch	
3	583 95 57-01	1	Tube, Exhaust Right	
4	583 95 56-01	1	Tube, Exhaust Left	
5	586 83 97-01	2	Gasket, Exhaust	
6	581 88 67-02	1	Bracket, Muffler Blk	
7	532 44 81-45	1	Arm, Idler	
8	582 53 89-01	1	Spindle, Idler	
9	539 11 03-11	1	Pulley, Idler	
10	587 53 74-01	1	Pulley, Engine	
11	587 66 01-01	1	Spacer	
12	539 13 28-59	1	Shield, Muffler	
13	587 63 33-02	1	Stop, Clutch Blk	
14	587 45 12-02	1	Guard, Muffler Blk	
15	539 13 16-04	1	Muffler Assembly	
16	532 19 61-05	1	Spring, Deck Drive	
17	584 82 55-01	2	Assy, Drain Hose	
18	539 10 13-63	1	Clamp	
19	522 59 90-01	1	Adapter, Oil Drain	
20	585 80 71-01	1	Plug, Oil w/ O-ring	
21	501 60 37-01	2	Bearing, Flanged	
22	582 53 95-01	1	Bolt 1/2-13 x 2-3/4 Hex Head	
23	874 52 06-56	1	Bolt 3/8-16 x 3-1/2 Hex Head	
24	872 14 05-06	2	Bolt 5/16-18 x 3/4 Rd Head Sq Neck	
25	872 14 05-08	2	Bolt 5/16-18 x 1 Rd Head Sq Neck	
26	581 33 28-04	1	Bolt 7/16-20 x 3-1/2 Hex Hd	
27	817 49 04-10	1	Screw 1/4-20 X 5/8 Thread Form	
28	874 78 06-20	4	Bolt 3/8-16 x 1-1/4	
29	817 49 05-12	4	Screw 5/16-18 x 3/4 Thread Form	
30	521 99 11-01	1	Nut 1/2-13 Hex Flange Nyloc	
31	539 11 28-99	5	Nut 5/16-18 Hex Flange Nyloc	
32	539 97 69-79	2	Nut 3/8-16 Hex Nyloc	
33	539 99 06-92	2	Washer 5/16 Std Flat	
34	532 12 61-97	1	Washer, Clutch	
35	810 03 06-00	4	Washer 3/8 Split Lock	
NOT SHOWN				
	589 54 39-01	1	Idler Arm Kit	7, 8, 9, 21, 22, 23, 32, 33
	-----	1	Engine, Kawasaki FR651V 21.5 HP For Engine Replacement Parts, See a Kawasaki Dealer	

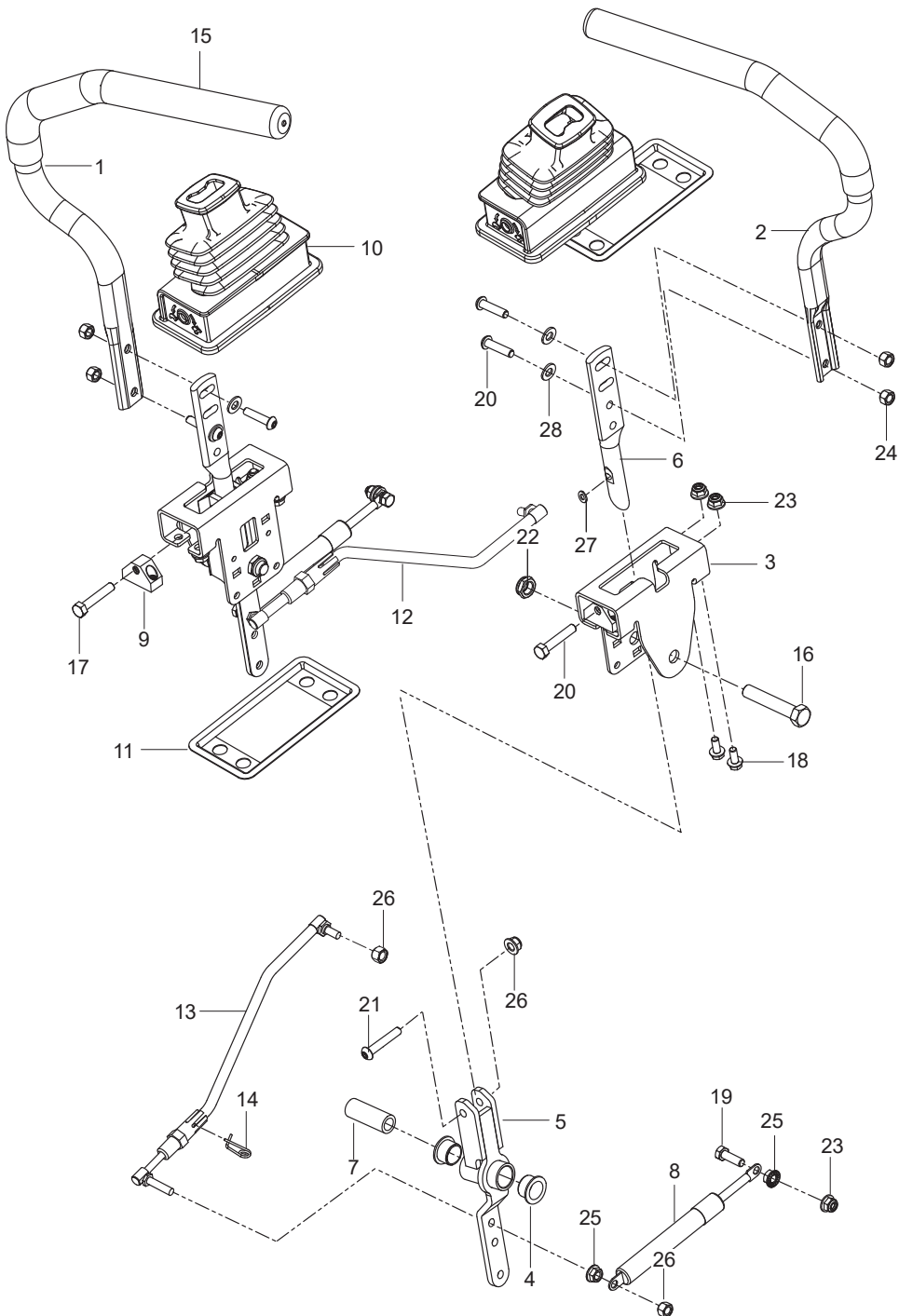

Ref.	Part No.	Qty	Description	Kit / Assy Includes
1	590 48 67-01	2	Assembly, Wheel Rear 18 x 8.5-8	
2	576 58 86-02	2	Wheel Assembly Caster 11 x 6.5	
3	586 65 03-02	2	Yoke Orange	
4	539 11 56-38	2	Zerk 3/16 Drive	
5	539 10 33-00	2	Zerk	
6	539 11 26-60	2	Bearing, Flanged	
7	539 11 79-01	2	Bushing, Caster	
8	539 10 25-35	2	Grease Cap	
9	539 11 57-49	2	Plug, Caster	
10	585 99 54-01	2	Spacer, Pivot	
11	539 11 57-47	2	Spring, Caster	
12	874 95 05-16	2	Bolt, Hex 5/16-18 x 1 Nylon Patch	
13	576 60 15-01	2	Bolt 1/2-13 x 7-1/2 Round Head Square Neck	
14	873 93 08-00	2	Nut 1/2-13 Hex Center Lock	
15	587 65 39-02	8	Nut 1/2 Lug	
16	539 11 56-75	2	Washer	
17	819 18 22-12	2	Washer 9/16	



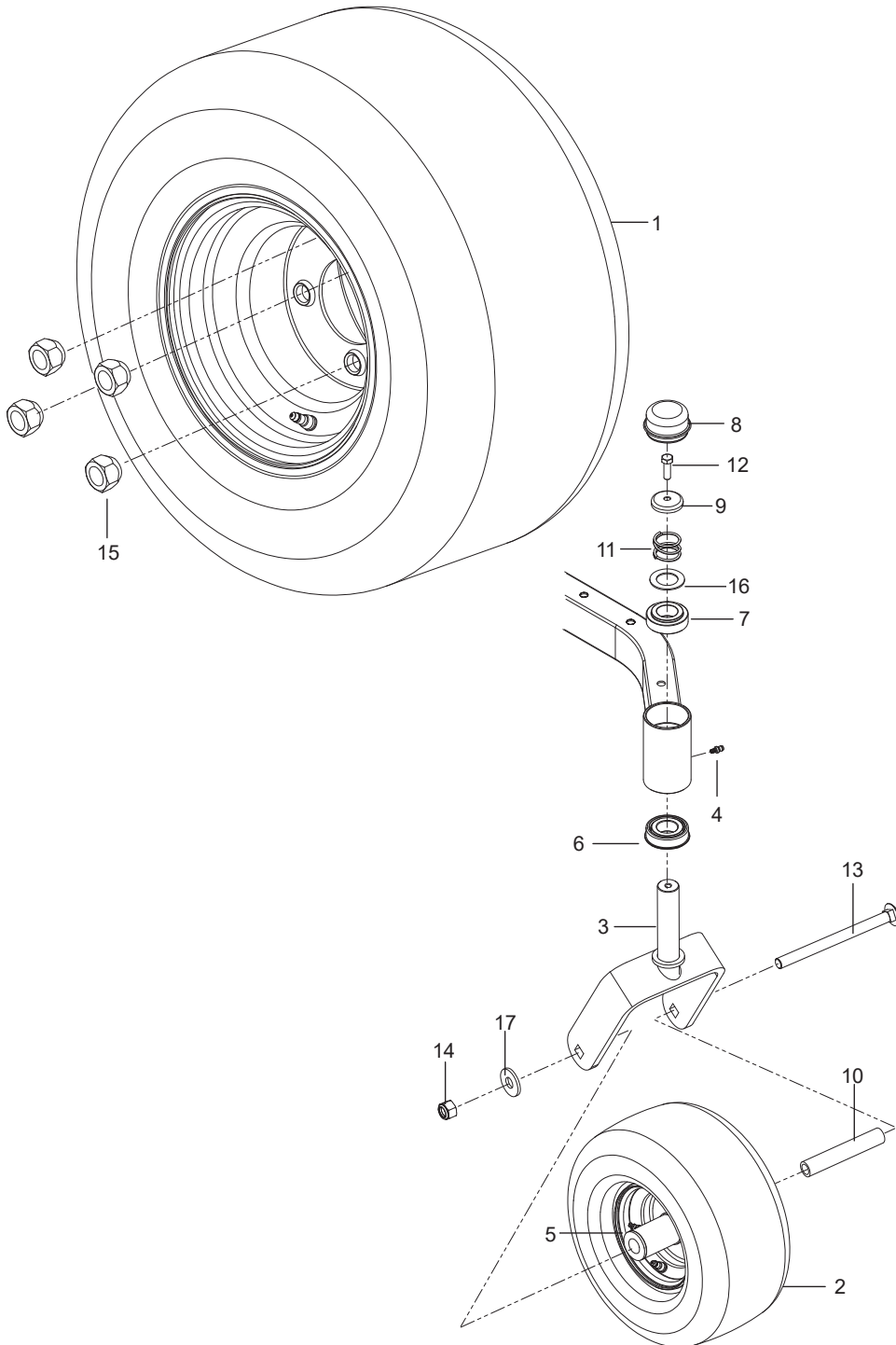

Ref.	Part No.	Qty	Description	Kit / Assy Includes
1	590 09 08-03	1	Lever w/ Grip Right Blk	
2	590 09 08-04	1	Lever w/ Grip Left Blk	
3	585 12 47-05	2	Bracket, Control	
4	539 13 15-18	4	Bearing, Flanged	
5	576 14 03-01	2	Control, Lever	
6	587 60 17-02	2	Lever, Handle	
7	584 92 72-01	2	Spacer, Pivot Control	
8	539 10 27-20	2	Dampener	
9	581 43 75-01	2	Block, Tracking	
10	585 83 16-01	2	Boot, Steering	
11	585 48 82-02	2	Flange, Boot	
12	588 60 49-01	2	Assy, Right Control Linkage	
13	588 60 50-01	2	Assy, Left Control Linkage	
14	532 19 98-49	2	Clip, Spring	
15	525 39 29-02	2	Grip, Foam	
16	874 78 08-44	2	Bolt 1/2-13 x 2-3/4 Hex Hd	
17	585 98 61-01	2	Bolt 5/16-18 x 1-1/4 Hex Hd	
18	874 49 05-12	8	Bolt Hex Flange 5/16-18 x 3/4	
19	539 99 02-09	4	Bolt 5/16-18 x 1 Thread Form	
20	585 98 59-01	4	Screw 5/16-18 x 1-1/4	
21	587 88 53-01	2	Screw 5/16-18 x 1-3/4	
22	539 10 80-10	2	Nut 1/2-13 Hex Jam Nyloc	
23	539 11 28-99	10	Nut 5/16-18 Hex Flange Nyloc	
24	585 98 60-01	4	Nut 5/16-18 Hex Nyloc Blk	
25	539 99 05-85	4	Nut 5/16-18 Hex Whiz Lock	
26	873 80 05-00	8	Nut 5/16-18 Hex Nyloc	
27	587 61 42-01	2	Washer 11/32	
28	586 30 91-01	4	Washer 5/16 SAE Flat Blk	

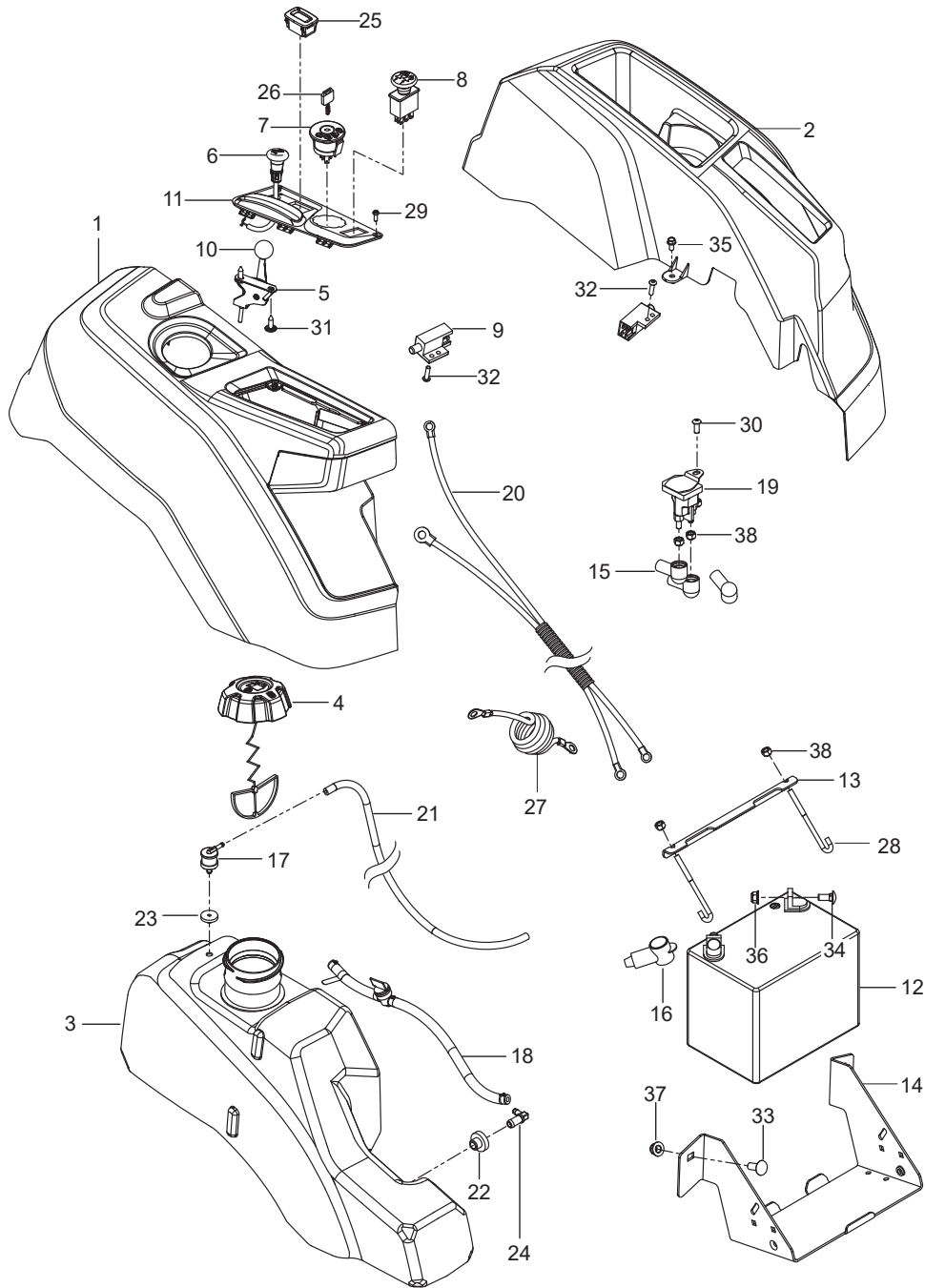

Ref.	Part No.	Qty	Description	Kit / Assy Includes
1	510 37 56-01	1	EZT, Left	
2	510 37 56-02	1	EZT, Right	
3	574 03 05-01	1	Rod, EZT Brake Left	
4	574 03 05-02	1	Rod, EZT Brake Right	
5	539 11 04-11	1	Belt, EZT	
6	585 47 44-01	1	Rod, Bypass Left	
7	585 47 45-01	1	Rod, Bypass Right	
8	586 66 51-01	2	Spring, Bypass	
9	539 11 03-42	2	Spring, Brake Rod	
10	539 12 00-80	2	Cog, Brake Disc	
11	539 12 00-79	2	Assembly Kit, Brake Arm	
12	575 50 70-01	1	Assembly Kit, Hub w/ Nuts	
13	501 40 36-02	2	Assembly Kit, Blade, Pulley	
14	510 18 41-04	2	Spacer Tube	
15	580 80 65-02	2	Support, EZT Front	
16	580 80 66-02	2	Mount, EZT Rear Blk	
17	587 22 53-01	1	Clip	
18	539 97 69-88	4	Clip	
19	587 11 53-01	1	Pin, Clevis	
20	874 78 05-44	4	Bolt 5/16-18 x 2-3/4	
21	539 97 69-34	2	Bolt 5/16-18 x 3/4	
22	874 78 05-36	2	Bolt 5/16-18 x 2-1/4	
23	539 99 06-37	4	Bolt 3/8-16 x 2-1/2	
24	873 80 05-00	8	Nut 5/16-18 Hex Nyloc	
25	539 97 69-78	2	Nut 1/4-20 Hex Nyloc	
26	819 11 11-16	16	Washer 5/16 SAE Flat	
27	810 03 06-00	4	Washer 3/8 Splt Lock	
28	819 13 13-16	8	Washer 3/8 SAE Flat	
29	819 09 10-16	4	Washer 1/4 SAE Flat	

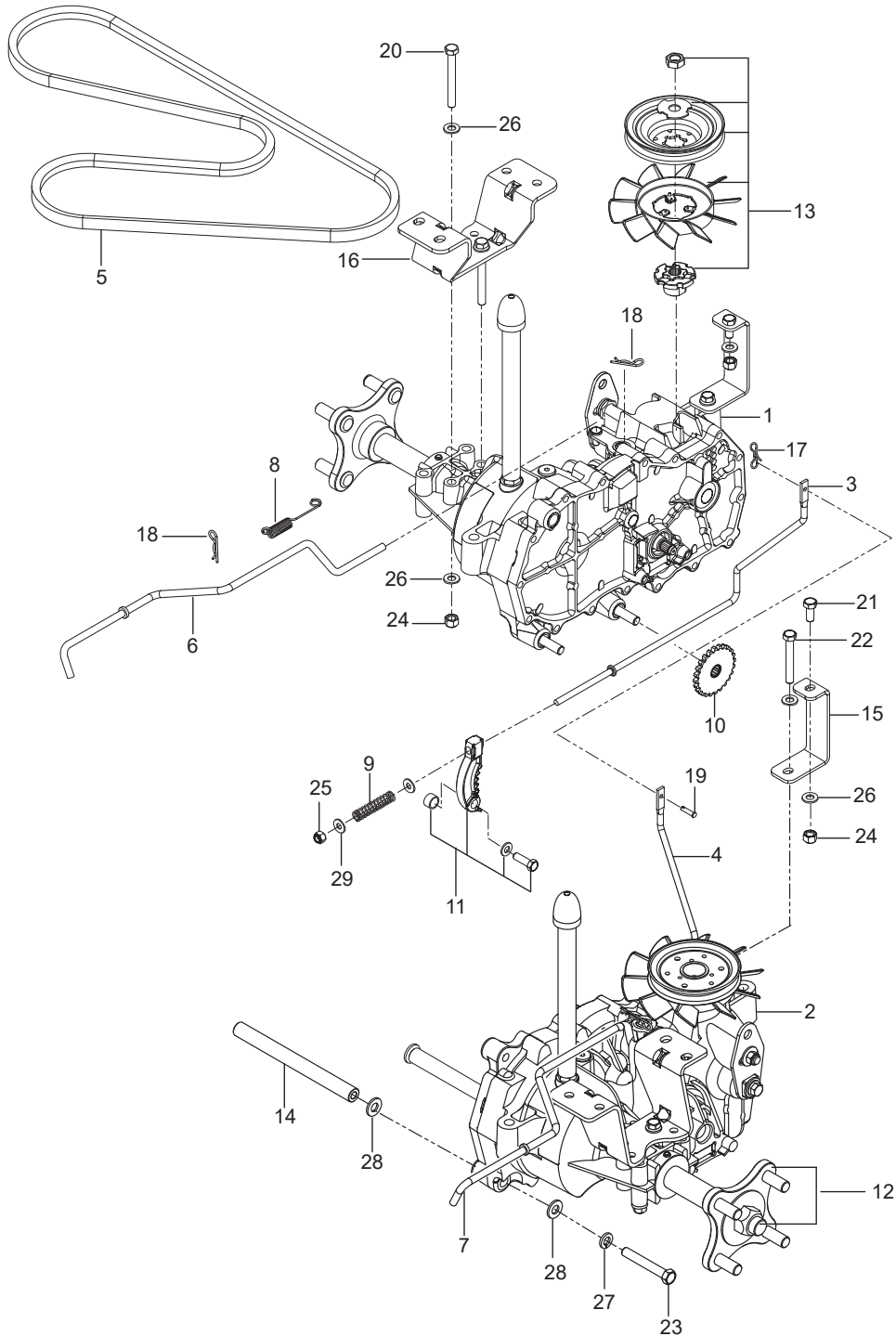

Ref.	Part No.	Qty	Description	Kit / Assy Includes
1	585 52 28-01	1	Assembly, Fender, Right Gry	
2	586 62 12 01	1	Assembly, Fender, Left Gry	
3	578 18 06-02	1	Assembly, Fuel Tank	22, 23, 24
4	585 12 48-01	1	Cap, Fuel w/ Tether	
5	539 11 24-38	1	Cable, Throttle	
6	586 88 15-01	1	Control, Choke	
7	539 10 75-41	1	Switch, Ignition	
8	582 10 76-02	1	Switch, Clutch	
9	587 60 15-01	2	Switch, Interlock	
10	539 13 30-49	1	Knob	
11	585 52 27-01	1	Panel, Control	
12	539 10 24-36	1	Battery	
13	510 03 00-03	1	Bracket, Battery	
14	582 60 96-02	1	Box, Battery Blk	
15	532 13 15-63	3	Terminal Cover	
16	539 10 27-59	1	Terminal Cover	
17	576 61 81-01	1	Valve, Fuel Check	
18	586 12 39-06	1	Assembly, Fuel Line w/ Valve	
19	582 04 28-01	1	Solenoid	
20	587 19 86-01	1	Harness, Battery Cable	
21	587 04 45-50	1	Hose 3/16 x 50" Vapor	
22	532 00 36-45	1	Grommet, Rubber	
23	532 43 74-92	1	Grommet, Check Valve	
24	532 13 92-77	1	Elbow	
25	586 16 18-01	1	Meter, Service	
26	532 14 04-01	1	Key, Ignition	
27	586 10 82-01	1	Cable, Battery Positive	
28	588 83 94-01	2	Hook, J	
29	545 22 71-01	2	Screw 6-19 x 7/16 Pan Hd	
30	539 11 12-29	1	Screw 1/4-20 x 5/8 Button Socket	
31	532 14 18-41	2	Screw 10-16 x .65	
32	586 93 60-01	2	Screw #10-24 x 1/2 Socket Hd	
33	539 99 06-45	2	Bolt 3/8-16 x 1 RH Square Neck	
34	872 14 05-06	2	Bolt 5/16-18 x 3/4 RH Square Neck	
35	817 49 04-08	2	Bolt 1/4-20 x 1/2	
36	539 11 28-99	2	Nut 5/16-18 Flange Nyloc	
37	521 99 65-01	2	Nut 3/8-16 Hex Flange Nyloc	
38	539 97 69-78	5	Nut 1/4-20 Hex Nyloc	
NOT SHOWN				
	586 33 73-01	1	Harness, Wiring	
	532 10 97-48	1	Relay 40A	
	586 54 81-01	1	Harness, LED Light	

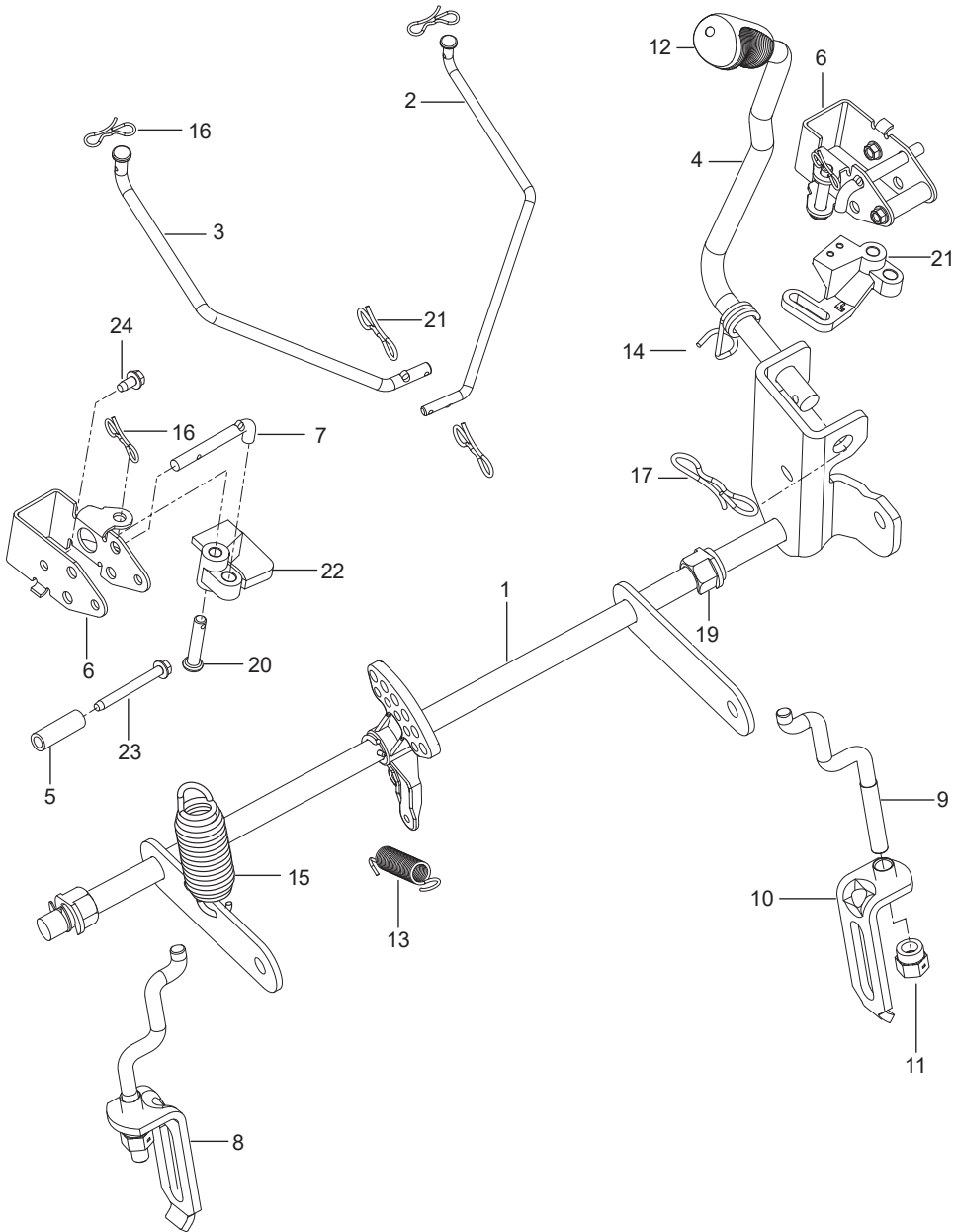

Ref.	Part No.	Qty	Description	Kit / Assy Includes
1	587 62 31-01	1	Assembly, Shaft w/ Nuts, E-Rings	19
2	586 45 71-01	1	Link, Brake Left	
3	586 45 72-01	1	Link, Brake Right	
4	587 62 29-01	1	Assembly, Lift Handle	12, 14, 17
5	580 48 61-01	2	Spacer	
6	585 68 21-02	2	Bracket, Bellcrank	
7	585 68 20-01	2	Pushrod	
8	587 62 30-01	2	Assembly, Centering Link	9, 10, 11
9	525 84 72-01	2	Link, Rear Suspension	
10	522 85 86-01	2	Bracket, Centering Link	
11	532 17 59-94	2	Nut, Lift Link	
12	532 44 50-60	1	Grip, Handle Black	
13	586 86 76-01	1	Spring	
14	532 19 63-14	1	Spring	
15	539 11 87-62	1	Spring	
16	587 22 53-01	4	Clip	
17	532 19 42-09	2	Pin, Cotter	
18	532 19 42-08	2	Clip	
19	510 18 49-01	2	Nut, Plastic	
20	585 70 14-01	2	Pin 1/2 Clevis	
21	586 45 74-01	1	Bellcrank Left	
22	586 45 75-01	1	Bellcrank Right	
23	586 56 13-01	2	Screw 1/4-20 x 2-1/4 Thread Roll	
24	532 13 77-29	2	Screw 1/4-20 x 5/8 Thread Roll	